



for latest edition
and updates **check**
www.powercapacitors.info



E51/E53/E55

AC/DC FILM CAPACITORS



HIGH VOLTAGES, HEAVY CURRENTS, AND LOW INDUCTANCE

ELECTRONICON[®]
always in charge

Choose the best capacitor
for any of your power electronics applications:

AC and DC capacitors with integrated safety mechanism
E62 AC/DC E62-3ph AC Filter E63 DC

Low-inductance capacitors
E50 PK16™ DC E53 AC/DC E61 DC

Low-inductance High-voltage capacitors
E51

AC and DC capacitors with large capacitance
E56 DC E59 AC/DC E70 AC E50.U SR17™ DC

CAPACITORS

ELECTRONICON®

always in charge

E51/E53/E55 AC/DC LOW-INDUCTANCE FILM CAPACITORS

NIEDERINDUKTIVE FOLIENKONDENSATOREN





E51

High voltage, low inductance, long-term safe operation

In power electronics in general, but particularly in low inductance buffer circuits with higher voltages and in discharge circuits, the call for capacitors with low inductance poses problems. Traditional high voltage capacitors are filled with oil, and the generous bushings required for clearance/creepage as well as internal safety mechanisms add substantially to the self-inductance of the capacitor.

Based on decades of proprietary experience in metallizing capacitor films, ELECTRONICON has created a range of high voltage capacitors in self-healing technology, using the opportunities of special metallizing patterns. Despite the high voltage ratings, our E51 range is made in dry technology and without expensive bushings. For the sake of optimised self-inductance, the E51s are made without safety mechanism; by clever internal design they can be laid out and rated in such manner that partial dielectric discharges and consequential risk of failures in the customer's application are reduced to a minimum.

E53/E55

All in one: High rms and surge currents combined with low self-inductance

Basically, the design of our E53 capacitors is very similar to E51. Using sophisticated metallizing patterns, our SINECUT™ slitting technology, and clever winding geometries, the E53 series has a particularly low series resistance and high pulse strength. Therefore they are especially suited for the damping of GTO thyristors and low-inductance buffer circuits with high rms currents. Their very low self-inductance makes them also suitable for use in high-current applications with medium frequencies.

Along with their very good ratio of capacitance to volume, the capacitors of the E51 and E53 product families do also have high pulse strength and very good self-healing characteristics without loss or shift of capacitance. The capacitors of our E55 series, which are very similar in design and electrical features, have been optimized particularly for large capacitances at high operating voltages.

All the capacitors described above are housed in flame-retardant plastic cans (V0) and filled with solid resin. Special care has been taken both in terms of design and conservative electrical rating to ensure reliable operation even under tough environmental conditions. Connection is usually made through robust axial terminals with internal thread. The E53H-range is based on the same construction and technology principles but allows for radial connection through robust studs with M8 thread; it has two brackets at the base of the can which make for convenient mounting.

E51

Hohe Spannungen, niedrige Induktivitäten, Langzeitbetrieb ohne Ausfälle

In der Leistungselektronik im allgemeinen, speziell in niederinduktiven Zwischenkreisen höherer Spannungen und in Entladeschaltungen ist die Forderung nach niederinduktiven Kondensatoren mit Problemen verbunden: Traditionelle Hochspannungskondensatoren sind mit Öl gefüllt, und die für die Luft- und Kriechstrecken großzügig auszubehenden Anschlussisolatoren wie auch der interne Sicherheitsmechanismus tragen wesentlich zur Eigeninduktivität des Kondensators bei.

Basierend auf jahrzehntelanger eigener Erfahrung bei der Metallisierung von Kondensatorfolien hat ELECTRONICON unter Nutzung spezieller Metallisierungsarten eine Reihe von Hochspannungskondensatoren in selbstheilender Technologie geschaffen. Trotz der hohen Spannungsnennwerte wird die E51 Reihe in trockener Technologie und ohne aufwändige Anschlüsse gefertigt. Im Interesse einer optimierten niedrigen Eigeninduktivität werden die E51er ohne Sicherheitsmechanismus gebaut; durch ein ausgeklügeltes Design können sie so ausgelegt und bemessen werden, dass dielektrische Teilentladungen und das resultierende Ausfallrisiko in der Anwendung des Kunden auf ein Minimum reduziert werden.

E53/E55

Alles in einem: hohe Effektiv- und Spitzenströme UND geringe Eigeninduktivität

Kondensatoren der E53-Reihe zeichnen sich durch einen besonders geringen Serienwiderstand und hohe Stoßstromfestigkeit aus. Durch die Nutzung einzigartiger Metallisierungsmuster, unsere SINECUT™ Schneidtechnologie und ausgeklügelte Wickelgeometrien eignen sie sich besonders zum Bedämpfen von GTO-Thyristoren und in Zwischenkreisen mit hohen Effektivströmen. Ihre sehr niedrige Eigeninduktivität ermöglicht darüber hinaus auch den Einsatz in Hochstrom-Anwendungen im mittleren Frequenzbereich.

Neben ihrem günstigen Verhältnis von Kapazität und Volumen zeichnen sich die Kondensatoren der E51- und E53-Produktfamilien durch eine sehr hohe Stoßstromfestigkeit und exzellente Selbstheilfähigkeit ohne Kapazitätsverluste oder -verschiebungen aus. Die in Aufbau und Eigenschaften sehr ähnlichen E55-Kondensatoren sind auf große Kapazitäten bei gleichzeitig hohen Spannungswerten optimiert.

Alle o.a. Kondensatoren sind in flammhemmenden Gehäusen (V0) untergebracht und mit Harz vergossen. Sowohl im Design als auch in der konservativen elektrischen Auslegung wurde großer Wert auf zuverlässiges Funktionieren auch unter schwierigen Umgebungsbedingungen gelegt. Der elektrische Anschluss wird über robuste axiale Anschlüsse mit Innengewinde hergestellt. Die E53H-Reihe basiert auf gleichem Aufbau und technologischen Prinzipien, erlaubt jedoch einen radialen Anschluss mittels M8-Gewinde; zwei Montagelaschen am Becherboden gewährleisten eine bequeme Befestigung.



E51
DC
1300...5600V DC

for latest edition and updates
check www.powercapacitors.info



Axial Low-inductance DC-Capacitors Niederinduktive Gleichspannungskondensatoren in axialer Bauform



Standards IEC 61071,
optional IEC 61881

can Gehäuse plastic Kunststoff (UL94: V0)

mounting position Einbaulage .. optional beliebig

filling material Füllmittel solid, based on vegetable oil, non-PCB
ausgehärtet, auf Pflanzenölbasis, PCB-frei

Internal protection none

Interne Sicherung keine

fire load Brandlast 40 MJ/kg

C_N tolerance Toleranz ±10% (optional ±5%)

tanδ₀ 2 × 10⁻⁴

operating temperatures Grenztemperaturen

Θ_{min} ... Θ_{max} -25 ... +70°C

Θ_{HOTSPOT} ≤ 70°C

storing temperature Lagertemperatur -40 ... +85°C

Failure rate Ausfallrate 50 FIT

(reference interval_Referenzintervall 100000 h, Θ_{ambipol} ≤ 70°C)



U _N DC (V)	C _N (µF)	U _r (V)	U _s (V)	U _{BB} DC (V)	R _s (mΩ)	R _{th} (K/W)	I _{max} (A)	Î (kA)	I _s (kA)	L _e (nH)	D ₁ × L ₁ (mm)	m (kg)	order no. Bestell-Nr.	pcs Stk / Box
U_N 1300V ... 2700V DC														
1300	700	300	1950	1950	0.39	3	80	9.3	28	30	140 × 175	2.8	E51.S18-704R20	2 / FB8
2300	80	400	4100	3795	1.3	3.6	50	4	13	80	64 × 355	1.2	E51.L35-803R20	10 / FB11
2300	170	400	4100	3450	0.6	2.4	90	6	17	100	90 × 355	2.4	E51.P35-174R20	5 / FB11
2500	25	800	3750	3750	0.96	6.4	70	3.1	9.3	30	90 × 130	0.9	E51.P13-253R20	10 / FB9
2500	50	800	3750	3750	1.3	4.9	70	3.1	9.3	50	90 × 170	1.1	E51.P17-503R20	5 / FB8
2700	40	500	4050	4455	0.85	2.55	40	5	15	20	140 × 125	2	E51.S12-403R20	4 / FB9
U_N 3000V ... 3600V DC														
3000	18	600	4500	4500	0.62	5.5	65	2.8	8.4	50	90 × 150	1.1	E51.P15-183R20	10 / FB10
3000	80	700	4500	4500	1.9	3.2	60	3.2	9.6	60	90 × 255	1.7	E51.P25-803R20	5 / FB9
3000	350	600	4500	4500	1.5	1.5	75	8.4	25.2	100	140 × 355	5.7	E51.S35-354R20	2 / FB13
3000	400	600	4500	4500	0.85	1.2	100	15.4	46.2	120	140 × 460	7.4	E51.S46-404R20	10 / FB26
3100	86	500	5600	5115	1.5	2.4	65	4.5	13	100	90 × 355	2.4	E51.P35-863R20	5 / FB11
3200	15	700	4800	5280	2.3	5.8	35	1	3	50	64 × 200	0.7	E51.L20-153R20	10 / FB8
3200	33	700	4800	5280	0.7	4.1	70	2.5	7.5	50	90 × 200	1.3	E51.P20-333R20	5 / FB8
3500	500	600	5250	5250	1.2	0.75	100	13.9	41.7	200	140 × 710	11.5	E51.S71-504R20	5 / FB22
3600	80	600	5400	5940	0.71	2.6	90	6	18	40	116 × 245	2.1	E51.R24-803R20	3 / FB12
3600	220	800	5400	5400	0.60	1.1	40	4.4	13.2	40	140 × 300	5	E51.S30-224R20	2 / FB9
U_N 4000V ... 5600V DC														
4000	8	2850	6000	6000	1.4	3.8	25	2.1	6.3	100	116 × 170	1.9	E51.R17-802R20	3 / FB8
4000	16	2850	6000	6000	1.1	3.1	30	3.8	11.4	100	140 × 170	2.7	E51.S17-163R20	2 / FB8
4000	215	800	6000	6000	0.7	0.95	100	11.9	35.7	60	140 × 565	9	E51.S56-224R20	4 / FB22
4200	8	800	6300	6930	4.3	8.3	15	0.69	2.07	60	64 × 138	0.5	E51.L14-802R20	10 / FB0
4200	45	800	6300	6930	1.6	2.4	50	4.2	12.6	80	90 × 355	2.4	E51.P35-453R20	5 / FB11
4400	8	950	6600	6600	4.2	6.5	20	0.85	2.55	60	64 × 180	0.6	E51.L18-802R20	10 / FB8
4400	8	950	6600	6600	1.4	6.4	20	1.7	5.1	50	90 × 130	0.9	E51.P13-802R20	10 / FB9
4500	300	850	6750	6750	1.1	0.75	100	16.5	49.5	200	140 × 710	11.5	E51.S71-304R20	5 / FB22
4700	187.5	1000	7050	7050	3.2	0.7	50	4.25	12.75	40	140 × 430	7	E51.S43-194R20	10 / FB26
5000	4.55	1000	7500	7500	6.5	7.8	15	0.47	1.41	60	64 × 150	0.5	E51.L15-462R20	10 / FB0
5600	1	1100	8400	8400	4.6	9.7	20	0.7	2.2	20	64 × 120	1	E51.L12-102R20	10 / FB0

Other values and dimensions available on request
Andere Werte und Abmessungen auf Anfrage erhältlich



E51
DC
6000...50000V DC

U _N DC (V)	C _N (µF)	U _r (V)	U _s (V)	U _{BB} DC (V)	R _s (mΩ)	R _{th} (K/W)	I _{max} (A)	Î (kA)	I _s (kA)	L _e (nH)	D ₁ × L ₁ (mm)	m (kg)	order no. Bestell-Nr.	pcs Stk / Box
U_N 6000V ... 9300V DC														
6000	30	700	9000	9000	2.3	3.2	30	2.1	6.3	80	116 × 200	2.2	E51.R20-303R20	3 / FB8
6200	6.8	1200	9300	9300	10	4.6	20	0.6	2	50	64 × 255	0.9	E51.L25-682R20	10 / FB9
6200	15	1200	9300	9300	4.6	3.2	35	1.5	4.5	50	90 × 255	1.7	E51.P25-153R20	5 / FB9
6300	20	1200	9450	9450	6.8	2.4	25	1.8	8	100	90 × 355	2.4	E51.P35-203R20	5 / FB11
6300	51.25	1200	9450	9450	2.7	1.5	40	4.3	20	80	140 × 355	5.7	E51.S35-513R20	2 / FB13
8000	5	1400	12000	12000	1.7	3.76	50	1.8	5	80	90 × 220	1.5	E51.P22-502R20	5 / FB8
8000	10	1400	12000	12000	2.3	2.59	50	1.9	6	100	90 × 320	2.2	E51.P32-103R20	5 / FB12
8000	40	1400	12000	12000	3.5	1.5	40	2.7	8.1	100	140 × 355	5.7	E51.S35-403R20	2 / FB13
8500	0.22	1400	12750	12750	6.9	7.1	20	0.9	2.9	50	64 × 165	0.6	E51.L16-221R20	10 / FB7
8500	0.5	3950	12750	12750	3.9	7.1	20	0.54	1.62	60	64 × 165	0.6	E51.L16-501R20	10 / FB7
8500	1	1400	12750	12750	2.5	5	25	1.7	5.1	50	90 × 165	1.1	E51.P16-102R20	5 / FB7
9300	9	1500	13950	13950	8	2.3	20	1	4	100	90 × 355	2.4	E51.P35-902R20	5 / FB11
9300	25	1500	13950	13950	2.7	1.5	40	4	11	100	140 × 355	5.7	E51.S35-253R20	2 / FB13
U_N 10000V ... 50000V DC														
10000	0.25	2000	15000	15000	15.2	7.1	10	1.1	3.3	80	64 × 165	0.6	E51.L16-251R20	10 / FB7
10000	4	2000	15000	15000	3.5	2	50	1.5	4.5	60	116 × 320	3.5	E51.R32-402R20	3 / FB10
10000	4.5	3000	15000	15000	1.8	1.1	50	8.8	26.4	100	140 × 480	8	E51.S48-452R20	4 / FB22
10000	10	2500	15000	15000	7	2.3	25	1.3	3.9	100	90 × 355	2.4	E51.P35-103R20	5 / FB11
12000	24	2100	18000	18000	4.2	0.95	25	4.2	12.6	60	140 × 565	9	E51.S56-243R20	4 / FB22
12500	0.22	2100	18750	18750	14	5.8	20	0.5	1.4	80	64 × 200	0.7	E51.L20-221R20	10 / FB8
12500	0.25	2100	18750	18750	14	5.8	20	0.5	1.5	80	64 × 200	0.7	E51.L20-251R20	10 / FB8
12500	1	2100	18750	18750	3.6	3.2	35	2	6	80	116 × 200	2.2	E51.R20-102R20	3 / FB8
13000	0.25	3000	19500	19500	17.7	4.1	10	0.6	1.7	100	64 × 285	1	E51.L28-251R20	10 / FB12
14000	5	2400	21000	21000	3.6	1.8	30	2.5	7.5	100	116 × 355	4	E51.R35-502R20	3 / FB11
14000	10	2400	21000	21000	2.4	1.5	40	4.3	12.9	120	140 × 355	5.7	E51.S35-103R20	2 / FB13
15000	1	3600	22500	22500	15.1	4.1	15	0.49	1.47	100	64 × 285	1	E51.L28-102R20	10 / FB12
15000	2	3600	22500	22500	7.2	2.9	20	1.1	3.3	200	90 × 285	1.9	E51.P28-202R20	5 / FB12
15000	10	3600	22500	22500	2.7	1.4	40	3.8	11.4	120	140 × 385	6.2	E51.S38-103R20	10 / FB26
15000	15	3600	22500	22500	2.8	1.2	40	4.6	13.8	120	140 × 460	7.4	E51.S46-153R20	4 / FB22
15000	20	3600	22500	22500	3.7	0.94	40	3.8	11.4	120	140 × 565	9.1	E51.S56-203R20	4 / FB22
20000	1.25	4000	30000	30000	11.7	2.3	20	0.9	2.7	100	90 × 355	2.4	E51.P35-132R20	5 / FB11
20000	1.5	4000	30000	30000	10.4	2.3	34	1.8	5.4	100	90 × 355	2.4	E51.P35-152R20	5 / FB11
25000	10	4600	37500	37500	3.9	0.75	35	4.3	12.9	200	140 × 710	11.5	E51.S71-103R20	5 / FB22
30000	1	4800	45000	45000	11	1.9	20	1	3	80	90 × 435	2.9	E51.P44-102R20	6 / FB23
30000	5	4800	45000	45000	7	0.75	35	2.8	8.4	200	140 × 710	11.5	E51.S71-502R20	5 / FB22
35000	0.2	5600	52500	52500	13.4	1.9	20	1	3	80	90 × 435	2.9	E51.P44-201R20	6 / FB23
35000	5	4800	52500	52500	5.5	0.7	25	3.2	9.6	200	140 × 785	12.7	E51.S78-502R20	4 / FB25
40000	2.2	8700	60000	52500*	5.3	0.84	35	2.8	8.4	180	140 × 630	10.2	E51.S63-222R20	5 / FB25
50000	0.5	10000	60000	52500**	5.8	0.75	35	2.9	8.7	200	140 × 710	11.5	E51.S71-501R20	5 / FB22



* additional test_Zusatzprüfung 14500V_{me}/10s
** additional test_Zusatzprüfung 16500V_{me}/10s



E51
AC/DC
2000...4300V AC / 3200...6000V DC

for latest edition and updates
 check www.powercapacitors.info



Axial Low-inductance AC/DC-Capacitors Niederinduktive Wechsel-/Gleichspannungskondensatoren in axialer Bauform



Standards IEC 61071,
 optional IEC 61881

can Gehäuse plastic Kunststoff (UL94: V0)
mounting position Einbauage.. optional beliebig
filling material Füllmittel solid, based on vegetable oil, non-PCB
 ausgehärtet, auf Pflanzenölbasis, PCB-frei

Internal protection none
 Interne Sicherung keine
fire load Brandlast 40 MJ/kg

C_N tolerance Toleranz ±10% (optional ±5%)
tanδ₀ 2 × 10⁻⁴

operating temperatures Grenztemperaturen
 Θ_{min} ... Θ_{max} -25 ... +70°C
 Θ_{HOTSPOT} ≤ 70°C

storing temperature Lagertemperatur..... -40 ... +85°C

Failure rate Ausfallrate 100 FIT
 (reference interval_Referenzintervall 100000 h, Θ_{HOTSPOT} ≤70°C)



U _N AC (V)	U _N DC (V)	C _N (µF)	U _{rms} (V)	U _S (V)	U _{BB} (V)	R _S (mΩ)	R _{th} (K/W)	I _{max} (A)	I ₁ (kA)	I _S (kA)	L _e (nH)	D ₁ × L ₁ (mm)	m (kg)	order no. Bestell-Nr.	pcs_Stk / Box
U_N 2000V ... 3250V AC U_{rms} 1650V ... 2300 V															
2350	4500	1.5	1650	6750	6750 (DC)	5.4	7.8	20	0.7	2	20	64 × 150	0.5	E51.L15-152R20	10 / FB0
2350		3	1650	3525	5053 (DC)	3	4.7	15	1.1	3.3	60	64 × 250	1	E51.L25-302R20	10 / FB9
2500	6000	1	1770	9000	5375 (DC)	3.2	6.4	28	0.98	2.94	30	90 × 130	0.9	E51.P13-102R20	10 / FB9
2550	3200	1	1800	4800	4800 (DC)	1.8	9.7	40	2	5	40	64 × 120	0.4	E51.L12-102R21	10 / FB0
2700	4400	4	1910	6600	6600 (DC)	0.62	5.8	90	2.2	7	15	116 × 110	1.5	E51.R11-402R20	6 / FB10
2900	5000	3	2050	7500	7500 (DC)	0.74	5.8	80	2	6	15	116 × 110	1.2	E51.R11-302R20	6 / FB10
3000		0.47	2100	6450	6450 (DC)	3.2	11.6	15	1.1	3.3	60	64 × 100	0.3	E51.L10-471R20	10 / FB1
3000		5	2200	7000	5000 (AC)	3.8	2.5	10	2	6	80	116 × 260	2.9	E51.R26-502R20	3 / FB12
3250		0.75	2300	4875	4875 (AC)	4.9	7.1	20	0.9	2.8	100	64 × 165	0.6	E51.L16-751R20	10 / FB7
3200	7280	0.5	2260	10920	10920 (DC)	5	9	25	0.62	1.86	60	64 × 130	0.4	E51.L13-501R20	10 / FB0
U_N 3500V AC U_{rms} 2500V															
3500	6000	0.22	2500	9000	9000 (DC)	4.8	9.7	20	0.7	2.1	60	64 × 120	0.4	E51.L12-221R20	10 / FB0
3500	6000	0.25	2500	9000	9000 (DC)	5.4	9.7	15	0.8	2.4	60	64 × 120	0.4	E51.L12-251R20	10 / FB0
3500	6000	0.33	2500	9000	9000 (DC)	3	9.7	20	1	2.9	60	64 × 120	0.4	E51.L12-331R20	10 / FB0
3500	6000	0.5	2500	9000	9000 (DC)	5.6	9.7	20	1	3	60	64 × 120	0.4	E51.L12-501R20	10 / FB0
3200	5450	0.68	2250	9000	9000 (DC)	4.6	9.7	20	1	2.9	60	64 × 120	0.4	E51.L12-681R20	10 / FB0
3500	6000	0.75	2500	9000	9000 (DC)	1.6	8.3	40	1.8	5.4	60	90 × 100	0.6	E51.P10-751R20	6 / FB10
3500	6000	1.25	2500	9000	9000 (DC)	2.2	6.4	45	1.4	4.2	60	90 × 130	0.9	E51.P13-132R20	10 / FB9
3500	6000	1.5	2500	9000	9000 (DC)	2.1	6.4	45	1.5	4.4	60	90 × 130	0.9	E51.P13-152R20	10 / FB9
2450	6000	2	1700	9000	9000 (DC)	2.8	5.9	45	1.5	4.4	60	90 × 140	1	E51.P14-202R20	10 / FB10
U_N 3850V ... 4300V AC U_{rms} 2700V ... 3050 V															
3850		2.5	2700	5775	7700 (DC)	4.1	2.9	25	2	6	100	90 × 285	1.9	E51.P28-252R20	5 / FB12
4200		1.1	3000	6300	9030 (DC)	2.7	5.5	20	1.6	4.8	50	90 × 150	1	E51.P15-112R20	10 / FB10
4300		0.5	3050	6450	9245 (DC)	5.3	7.1	15	0.8	2.3	100	64 × 165	0.6	E51.L16-501R21	10 / FB7
4300		0.8	3050	6450	9245 (DC)	7.5	5.8	15	0.9	2.7	100	64 × 200	0.7	E51.L20-801R20	10 / FB8

Other values and dimensions available on request
 Andere Werte und Abmessungen auf Anfrage erhältlich



E51
AC/DC
4550...35000V AC / 6000...50000V DC

U_N AC (V)	U_N DC (V)	C_N (μ F)	U_{rms} (V)	U_S (V)	U_{BB} (V)	R_S (m Ω)	R_{th} (K/W)	I_{max} (A)	\hat{I} (kA)	I_S (kA)	L_e (nH)	$D_1 \times L_1$ (mm)	m (kg)	order no. Bestell-Nr.	pcs_Stk / Box
U_N 4550V AC			U_{rms} 3200V												
4550	7280	0.22	3200	10920	10920 (DC)	8.9	9	15	0.34	1.02	60	64 × 130	0.5	E51.L13-221R20	10 / FB0
4550	7280	0.33	3200	10920	10920 (DC)	6.7	9	20	0.46	1.38	60	64 × 130	0.5	E51.L13-331R20	10 / FB0
3150	7280	0.75	2200	10920	10920 (DC)	3	6.4	40	1	3	60	90 × 130	0.9	E51.P13-751R20	10 / FB9
2500	6000	1	1770	9000	10750 (DC)	3.2	6.4	28	0.98	2.94	30	90 × 130	0.9	E51.P13-102R20	10 / FB9
4400	6800	1.5	3100	10200	10200 (DC)	2.3	5.5	25	1	3	50	90 × 150	1	E51.P15-152R21	10 / FB10
4550		1.1	3200	6825	6880 (AC)	3.6	3	20	2.4	7.2	80	90 × 275	1.9	E51.P27-112R20	5 / FB12
2800	4400	1.25	2000	10920	10920 (DC)	4.5	6.4	40	1.2	3.6	60	90 × 140	1	E51.P14-132R20	10 / FB10
4550	7280	1.5	3200	10920	10920 (DC)	2	4.9	50	2.1	6.3	60	116 × 130	1.1	E51.R13-152R20	6 / FB10
4550	7280	2	3200	10920	10920 (DC)	1.8	4.9	55	2.4	7.2	60	116 × 130	1.1	E51.R13-202R20	6 / FB10
U_N 4700V ... 5850V AC			U_{rms} 3300V ... 4150 V												
4700		0.75	3300	7050	4460 (AC)	7.5	4.7	15	0.9	2.7	60	64 × 250	1	E51.L25-751R20	10 / FB9
5000		0.47	3500	10750	10750 (DC)	5.8	5.5	16	1	3	40	64 × 210	0.8	E51.L21-471R20	10 / FB8
5000	10000	0.5	3540	15000	15000 (DC)	5.7	4.1	25	1	3	50	90 × 200	1.3	E51.P20-501R20	5 / FB8
5000		1	3540	7500	10750 (DC)	5.8	3.25	25	1.2	3.6	50	90 × 255	1.7	E51.P25-102R20	5 / FB9
5100		1.6	3600	9500	7100 (AC)	4	1.8	25	5	15	120	116 × 355	3.9	E51.R35-162R20	3 / FB11
5100		2.4	3600	10965	10965 (DC)	3	4.1	35	1.4	4.2	60	90 × 200	1.3	E51.P20-242R21	5 / FB8
5100		2.6	3600	9500	7100 (AC)	3.8	1.4	25	5	15	120	116 × 460	4.9	E51.R46-262R20	6 / FB23
5200		1.1	3700	7800	11180 (DC)	3.1	4.1	20	5.1	3.1	60	90 × 200	1.3	E51.P20-112R20	5 / FB8
5850		0.47	4150	12580	12580 (DC)	3.5	5	20	2.2	6.6	60	90 × 165	1.2	E51.P16-471R20	5 / FB8
U_N 6000V ... 9620V AC			U_{rms} 4600V ... 6800 V												
6300	9000	0.13		13500	13545 (DC)	5.5	7.1	20	0.8	2.4	100	64 × 165	0.6	E51.L16-131R20	10 / FB7
6300	9000	0.14		13500	13545 (DC)	17.6	5.8	14	0.3	0.9	50	64 × 200	0.7	E51.L20-141R20	10 / FB8
6500		4	4600	9500	14000 (DC)	1.7	1.5	12	7	21	150	140 × 355	5.7	E51.S35-402R20	2 / FB13
7500		1.33	5300	11250	16125 (DC)	3.9	1.5	10	2.5	7.5	100	140 × 355	5.7	E51.S35-132R20	2 / FB13
8900		0.24	6300	13350	19200 (DC)	5	3.94	20	2	6	60	90 × 210	1.4	E51.P21-241R20	5 / FB8
9200		0.5	6510	13800	13800 (AC)	3.9	3	10	1.7	5.1	80	90 × 275	1.9	E51.P27-501R20	5 / FB12
9620		0.5	6800	14430	10200 (AC)	3	2.6	40	3.7	11.1	60	116 × 250	2.9	E51.R25-501R20	3 / FB9
U_N 10000V ... 35000V AC			U_{rms} 7100V ... 25000 V												
10000	14000	1	7100	15000	8875 (AC)	3.4	1.7	25	3.7	11.1	100	116 × 390	4	E51.R39-102R20	6 / FB23
10000	14000	1.9	7100	15000	8875 (AC)	2.1	1.4	25	6.2	18.6	100	140 × 390	6	E51.S39-192R20	10 / FB26
12750		0.2	9000	27400	27400 (DC)	7	2.3	20	2.3	6.9	100	90 × 355	2.4	E51.P35-201R20	5 / FB11
10000		0.5	7070	15000	21500 (DC)	7.2	1.44	10	1	3	100	90 × 355	2.4	E51.P35-501R20	5 / FB11
20000	26000	0.3	14000	30000	43000 (DC)	3.1	1.8	10	8	20	100	116 × 355	3.9	E51.R35-301R20	3 / FB11
20000	30000	1	14140	45000	52500 (DC)	5.7	0.7	10	4.9	14.7	200	140 × 710	11.5	E51.S71-102R20	5 / FB22
20000	50000	0.5	14140	60000	50000 (AC)	6.2	0.7	10	8.5	20	200	140 × 710	11.5	E51.S71-501R20	5 / FB22



E53
AC/DC
280...350V AC / 550...1100V DC

for latest edition and updates
 check www.powercapacitors.info



Axial Low-inductance AC/DC-Capacitors Niederinduktive
 Wechsel-/Gleichspannungskondensatoren in axialer Bauform

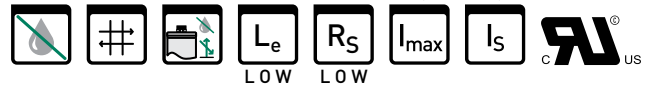

Standards IEC 61071, UL810, CSA 22.2 No.190
 optional IEC 61881

can Gehäuse plastic Kunststoff (UL94: V0)

mounting position Einbaulage.. optional beliebig

filling material Füllmittel solid, based on vegetable oil, non-PCB
 ausgehärtet, auf Pflanzenölbasis, PCB-frei

Internal protection none

Interne Sicherung keine

fire load Brandlast 40 MJ/kg

C_N tolerance Toleranz ±10% (optional ±5%)

self-inductance Eigeninduktivität L_e ca. 15 nH

tanδ₀ 2 × 10⁻⁴

operating temperatures Grenztemperaturen

Θ_{min} ... Θ_{max} -40 ... +85°C

Θ_{HOTSPOT} ≤ 85°C

storing temperature Lagertemperatur -40 ... +85°C

Failure rate Ausfallrate 100 FIT

(reference interval_Referenzintervall 100000 h, Θ_{HOTSPOT} ≤ 70°C)



C _N (μF)	R _S (mΩ)	L _e (nH)	R _{th} (K/W)	I _{max} (A)	I _{hat} (kA)	I _S (kA)	D ₁ × L ₁ (mm)	Design Maßbild	m (kg)	L/K (mm)	order no. Bestell-Nr.	pcs_Stk / Box
U_N 550V DC / 280V AC												
				U_{rms} 200V		U_S 825V		U_{BB} 825V DC				
50	0.8	15	8.5	60	0.83	2.5	55 × 56	T1	0.18	97	E53.H56-503T10	15 / FB6
100	0.4	15	6.3	80	1.7	5	75 × 56	T2	0.33	111	E53.M56-104T20	10 / FB2
200	0.2	15	4.9	80	3.3	9.9	95 × 56	T2	0.52	131	E53.P56-204T20	10 / FB2
250	0.15	15	4.5	80	3.3	10	105 × 56	T2	0.64	141	E53.Q56-204T20	10 / FB2
270	0.15	15	4.1	100	3.3	10	115 × 56	T2	0.77	151	E53.R56-274T20	12 / FB2
380	0.31	15	2.3	100	3	10	115 × 100	T2	1.37	195	E53.R10-384T20	6 / FB2
U_N 700V DC / 350V AC												
				U_{rms} 250V		U_S 1050V		U_{BB} 1050V DC				
33	0.95	15	8.5	55	0.68	2.1	55 × 56	T1	0.18	97	E53.H56-333T10	15 / FB6
68	0.5	15	6.3	80	1.4	4.2	75 × 56	T2	0.33	111	E53.M56-683T20	10 / FB2
120	0.3	15	4.9	80	2.5	7.4	95 × 56	T2	0.52	131	E53.P56-124T20	10 / FB2
150	0.25	15	4.5	100	3.1	9.3	105 × 56	T2	0.64	141	E53.Q56-154T20	10 / FB2
200	0.2	15	4.1	100	3.1	10	115 × 56	T2	0.77	151	E53.R56-204T20	12 / FB9
310	0.3	15	2.3	100	3	10	115 × 100	T2	1.37	195	E53.R10-314T20	6 / FB8
U_N 900V DC / 350V AC												
				U_{rms} 250V		U_S 1350V		U_{BB} 1350V DC				
30	0.85	15	8.5	60	0.68	2.1	55 × 56	T1	0.18	97	E53.H56-303T10	15 / FB6
60	0.5	15	6.3	80	1.4	4.1	75 × 56	T2	0.33	111	E53.M56-603T20	10 / FB2
100	0.35	15	4.9	80	2.3	6.8	95 × 56	T2	0.52	131	E53.P56-104T20	10 / FB2
120	0.2	15	4.5	100	2.8	9	105 × 56	T2	0.64	141	E53.Q56-124T20	10 / FB2
140	0.2	15	4.1	100	3.1	10	115 × 56	T2	0.77	151	E53.R56-144T20	12 / FB9
265	0.35	15	2.3	110	3	9	115 × 100	T2	1.37	195	E53.R10-274T20	6 / FB9
U_N 1100V DC / 350V AC												
				U_{rms} 250V		U_S 1650V		U_{BB} 1650V DC				
12	1.7	15	8.5	40	0.40	1.2	55 × 56	T1	0.18	97	E53.H56-123T10	15 / FB6
15	1.1	15	8.5	40	0.5	1.5	55 × 56	T1	0.18	97	E53.H56-153T10	15 / FB6
25	0.71	15	6.3	70	0.83	2.5	75 × 56	T2	0.33	111	E53.M56-253T20	10 / FB2
50	0.34	15	4.9	80	1.7	5	95 × 56	T2	0.52	131	E53.P56-503T20	10 / FB2
60	0.35	15	4.5	100	2.0	6	105 × 56	T2	0.64	141	E53.Q56-603T20	10 / FB2
80	0.21	15	4.1	100	3	10	115 × 56	T2	0.77	151	E53.R56-803T20	12 / FB9
175	0.41	15	2.3	100	2.6	8	115 × 100	T2	1.37	195	E53.R10-184T20	6 / FB9

Other values and dimensions available on request

Andere Werte und Abmessungen auf Anfrage erhältlich



E53
AC/DC
350...700V AC / 1400...2800V DC

C_N (μF)	R_s ($\text{m}\Omega$)	L_e (nH)	R_{th} (K/W)	I_{max} (A)	\hat{I} (kA)	I_s (kA)	$D_1 \times L_1$ (mm)	Design Maßbild	m (kg)	L/K (mm)	order no. Bestell-Nr.	pcs_Stk / Box
U_N 1400V DC / 350V AC				U_{rms} 250V		U_s 2100V		U_{BB} 2100V DC				
8	2	15	8.5	38	0.33	1	55 × 56	T1	0.18	97	E53.H56-802T10	15 / FB6
16	1	15	6.3	80	0.66	2	75 × 56	T2	0.33	111	E53.M56-163T20	10 / FB2
30	0.55	15	4.9	80	1.2	3.7	95 × 56	T2	0.52	131	E53.P56-303T20	10 / FB2
40	0.4	15	4.5	100	1.7	5	105 × 56	T2	0.64	141	E53.Q56-403T20	10 / FB2
50	0.3	15	4.1	100	2.2	10	115 × 56	T2	0.77	151	E53.R56-503T20	12 / FB9
110	0.52	15	2.3	100	2	6	115 × 100	T2	1.37	195	E53.R10-114T20	6 / FB8
U_N 1700V DC / 700V AC				U_{rms} 500V		U_s 2550V		U_{BB} 2550V DC				
4.7	1.3	15	8.5	45	0.5	1.6	55 × 56	T1	0.18	97	E53.H56-472T10	15 / FB6
10	0.6	15	6.3	80	1.1	3.5	75 × 56	T2	0.33	111	E53.M56-103T20	10 / FB2
16	0.37	15	4.9	80	1.8	5.5	95 × 56	T2	0.52	131	E53.P56-163T20	10 / FB2
22	0.27	15	4.5	100	2.5	7.5	105 × 56	T2	0.64	141	E53.Q56-223T20	10 / FB2
33	0.2	15	4.1	100	3.5	10	115 × 56	T2	0.77	151	E53.R56-333T20	12 / FB9
68	0.35	15	2.3	100	3.1	9.3	115 × 100	T2	1.37	195	E53.R10-683T20	6 / FB8
U_N 2000V DC / 700V AC				U_{rms} 500V		U_s 3000V		U_{BB} 3000V DC				
3.3	1.6	15	8.5	40	0.42	1.2	55 × 56	T1	0.18	97	E53.H56-332T10	15 / FB6
8	0.65	15	6.3	80	1	3	75 × 56	T2	0.33	111	E53.M56-802T20	10 / FB2
14	0.35	15	4.9	80	1.8	5.5	95 × 56	T2	0.52	131	E53.P56-143T20	10 / FB2
18	0.3	15	4.5	100	2.3	7	105 × 56	T2	0.64	141	E53.Q56-183T20	10 / FB2
24	0.2	15	4.1	100	3	10	115 × 56	T2	0.77	151	E53.R56-243T20	12 / FB9
52.5	0.39	15	2.3	100	2.8	8	115 × 100	T2	1.37	195	E53.R10-533T20	6 / FB8
U_N 2250V DC / 700V AC				U_{rms} 500V		U_s 3375V		U_{BB} 3375V DC				
2.5	1.8	15	8.5	40	0.37	1.1	55 × 56	T1	0.18	97	E53.H56-252T10	15 / FB6
6	0.76	15	6.3	70	0.88	2.6	75 × 56	T1	0.33	111	E53.M56-602T20	10 / FB2
10	0.46	15	4.9	80	1.5	4.5	95 × 56	T2	0.52	131	E53.P56-103T20	10 / FB2
15	0.27	15	4.5	100	2.1	6.2	105 × 56	T2	0.64	141	E53.Q56-153T20	10 / FB2
18	0.25	15	4.1	100	2.6	10	115 × 56	T2	0.77	151	E53.R56-183T20	12 / FB9
40	0.45	15	2.3	100	2.4	7	115 × 100	T2	1.37	195	E53.R10-403T20	6 / FB8
U_N 2800V DC / 700V AC				U_{rms} 500V		U_s 4200V		U_{BB} 4200V DC				
1.5	2.4	15	8.5	32	0.27	1.4	55 × 56	T1	0.18	97	E53.H56-152T10	15 / FB6
3.3	1.1	15	6.3	60	0.6	3	75 × 56	T2	0.33	111	E53.M56-332T20	10 / FB2
7.5	0.5	15	4.9	80	1.5	7.5	95 × 56	T2	0.52	131	E53.P56-752T20	10 / FB2
10	0.4	15	4.5	100	1.8	9	105 × 56	T2	0.64	141	E53.Q56-103T20	10 / FB2
12	0.3	15	4.1	100	2.2	12	115 × 56	T2	0.77	151	E53.R56-123T20	12 / FB9
25	0.57	15	2.3	100	1.9	6	115 × 100	T2	1.37	195	E53.R10-253T20	6 / FB8



E53

AC/DC

1050...2450V AC / 3200... 7200V DC



C_N (μF)	R_s ($m\Omega$)	L_e (nH)	R_{th} (K/W)	I_{max} (A)	\hat{i} (kA)	I_s (kA)	$D_1 \times L_1$ (mm)	Design Maßbild	m (kg)	L/K (mm)	order no. Bestell-Nr.	pcs_Stk / Box
U_N 3200V DC / 1050V AC				U_{rms} 750V		U_s 4800V		U_{BB} 4800V DC				
1	1.6	15	8.5	40	0.35	1.8	55 × 56	T1	0.18	97	E53.H56-102T10	15 / FB6
2.5	0.65	15	6.3	75	0.9	4.5	75 × 56	T2	0.33	111	E53.M56-252T20	10 / FB2
4	0.4	15	4.9	80	1.5	7.5	95 × 56	T2	0.52	131	E53.P56-402T20	10 / FB2
6	0.28	15	4.5	100	2.2	11	105 × 56	T2	0.64	141	E53.Q56-602T20	10 / FB2
7	0.25	15	4.1	100	3	12	115 × 56	T2	0.77	151	E53.R56-702T20	12 / FB9
U_N 2450V DC / 1400V AC				U_{rms} 1000V		U_s 3675V		U_{BB} 3675V DC				
1.16	1.2	15	8.5	20	0.7	2.2	55 × 56	T1	0.18	97	E53.H56-122T10	15 / FB6
2.4	0.56	15	6.3	60	1.5	5	75 × 56	T2	0.33	111	E53.M56-242T20	10 / FB2
4.2	0.32	15	4.9	80	2.6	8	95 × 56	T2	0.52	131	E53.P56-422T20	10 / FB2
5.2	0.26	15	4.5	100	3	10	105 × 56	T2	0.64	141	E53.Q56-522T20	10 / FB2
6.4	0.21	15	4.1	100	4	12	115 × 56	T2	0.77	151	E53.R56-642T20	12 / FB9
U_N 3600V DC / 1400V AC				U_{rms} 1000V		U_s 5400V		U_{BB} 5400V DC				
8	0.52	15	2.3	100	2.3	6.9	115 × 100	T2	1.37	195	E53.R10-802T20	6 / FB8
10	0.94	15	2.3	100	2.5	7.5	115 × 100	T2	1.37	195	E53.R10-103T20	6 / FB8
U_N 3750V DC / 2100V AC				U_{rms} 1500V		U_s 5625V		U_{BB} 5625V DC				
0.47	2.9	15	8.5	20	0.7	2.1	55 × 56	T1	0.18	97	E53.H56-471T10	15 / FB6
1.1	1.2	15	6.3	60	1.6	5	75 × 56	T2	0.33	111	E53.M56-112T20	10 / FB2
1.7	0.8	15	4.9	80	2.5	8	95 × 56	T2	0.52	131	E53.P56-172T20	10 / FB2
2.15	0.64	15	4.5	100	3	10	105 × 56	T2	0.64	141	E53.Q56-222T20	10 / FB2
2.7	0.51	15	4.1	100	4	12	115 × 56	T2	0.77	151	E53.R56-272T20	12 / FB9
U_N 5000V DC / 2100V AC				U_{rms} 1500V		U_s 7500V		U_{BB} 7500V DC				
3	1.2	15	2.3	125	2.1	6.3	115 × 100	T2	1.37	195	E53.R10-302T21	6 / FB8
4	1	15	2.3	125	2.5	7.5	115 × 100	T2	1.37	195	E53.R10-402T21	6 / FB8
U_N 5600V DC / 2450V AC				U_{rms} 1750V		U_s 8400V		U_{BB} 8400V DC				
0.22	13.7	15	4.9	25	0.2	0.7	55 × 97	T1	0.31	138	E53.H97-221T10	18 / FB3
0.25	12.1	15	4.9	25	0.3	0.8	55 × 97	T1	0.32	138	E53.H97-251T10	18 / FB3
0.5	8	15	4.9	25	0.4	1.3	55 × 97	T1	0.33	138	E53.H97-501T10	18 / FB3
U_N 7200V DC / 2450V AC				U_{rms} 1750V		U_s 10800V		U_{BB} 10800V DC				
0.22	13.7	15	4.9	25	0.2	0.7	55 × 97	T1	0.31	138	E53.H97-221T11	18 / FB3
0.25	12.1	15	4.9	25	0.3	0.8	55 × 97	T1	0.32	138	E53.H97-251T11	18 / FB3

Other values and dimensions available on request
Andere Werte und Abmessungen auf Anfrage erhältlich





for latest edition and updates
check www.powercapacitors.info

E53 H/E55

DC
600...1300V DC

Low-inductance DC-Capacitors
Niederinduktive Gleichspannungskondensatoren

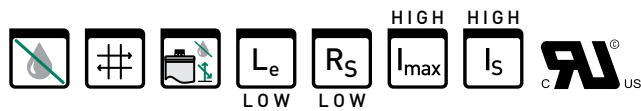

Standards IEC 61071, UL810, CSA 22.2 No.190
optional IEC 61881

can Gehäuse plastic Kunststoff (UL94: V0)

mounting position Einbaulage .. optional beliebig

filling material Füllmittel solid, based on vegetable oil, non-PCB
ausgehärtet, auf Pflanzenölbasis, PCB-frei

Internal protection none

Interne Sicherung keine

fire load Brandlast 40 MJ/kg

C_N tolerance Toleranz ±10% (optional ±5%)
tanδ₀ 2 × 10⁻⁴

operating temperatures Grenztemperaturen

Θ_{min} ... Θ_{max} -40 ... +85°C
(E53 H: -25°C)

Θ_{HOTSPOT} ≤ 85°C

storing temperature Lagertemperatur -40 ... +85°C

Failure rate Ausfallrate 50 FIT
(reference interval_Referenzintervall 100000 h, Θ_{HOTSPOT} ≤ 70°C)

C _N (µF)	U _r (V)	R _s (mΩ)	R _{th} (K/W)	I _{max} (A)	İ (kA)	I _s (kA)	L _e (nH)	D ₁ × L ₁ (mm)	Design Maßbild	m (kg)	L/K (mm)	order no. Bestell-Nr.	pcs_Stk / Box
U_N 600V DC		U_s 900V		U_r (see chart)		U_{BB} 900V DC							
200	100	0.75	6.1	60	3.3	9.9	30	85 × 51	H1	0.36	29/33	E53.N51-204H11	8 / FB6
280	100	0.84	4.8	60	3.5	10.5	35	85 × 64	H1	0.45	29/33	E53.N64-284H10	8 / FB4
400	100	1.1	4.1	60	3.3	9.9	40	85 × 76	H1	0.53	29	E53.N76-404H11	8 / FB4
U_N 700V DC		U_s 1050V		U_r (see chart)		U_{BB} 1050V DC							
150	160	0.7	6.1	60	2.9	8.7	30	85 × 51	H1	0.36	29/33	E53.N51-154H11	8 / FB6
200	160	0.92	4.8	60	2.9	8.7	35	85 × 64	H1	0.45	29/33	E53.N64-204H10	8 / FB4
300	160	1.2	4.1	60	2.9	8.7	40	85 × 76	H1	0.53	29	E53.N76-304H11	8 / FB4
U_N 900V DC		U_s 1350V		U_r (see chart)		U_{BB} 1350V DC							
47	200	0.58	8.5	45	0.8	2.3	15	55 × 56	T1	0.18	97	E55.H56-473T10	15 / FB6
120	200	0.84	6.1	60	2.6	7.9	30	85 × 51	H1	0.36	29/33	E53.N51-124H11	8 / FB6
150	200	1	4.8	60	2.5	7.5	35	85 × 64	H1	0.45	29/33	E53.N64-154H11	8 / FB4
240	200	1.3	4.1	60	2.6	7.8	40	85 × 76	H1	0.53	29	E53.N76-244H11	8 / FB4
250	280	0.35	4.5	100	8.3	24.9	15	105 × 56	T2	0.64	141	E55.Q56-254T20	10 / FB2
U_N 1100V DC		U_s 1650V		U_r (see chart)		U_{BB} 1650V DC							
75	250	1	6.1	60	2	6	30	85 × 51	H1	0.36	29/33	E53.N51-753H11	8 / FB6
100	250	0.9	4.8	60	2	6.2	35	85 × 64	H1	0.45	29/33	E53.N64-104H10	8 / FB4
150	250	1.5	4.1	75	2	6.1	40	85 × 76	H1	0.53	29	E53.N76-154H11	8 / FB4
U_N 1300V DC		U_s 1950V		U_r (see chart)		U_{BB} 1950V DC							
50	300	1.1	6.1	70	1.6	4.8	30	85 × 51	H1	0.36	29/33	E53.N51-503H11	8 / FB6
50	400	0.98	6.3	65	2.4	7.2	15	75 × 56	T2	0.33	111	E55.M56-503T20	10 / FB2
68	300	1.3	4.8	70	1.7	5.1	35	85 × 64	H1	0.45	29/33	E53.N64-683H10	8 / FB4
90	400	0.55	4.9	80	4.3	12.9	15	95 × 56	T2	0.52	131	E55.P56-903T20	10 / FB2
100	300	1.5	4.1	60	1.6	4.8	40	85 × 76	H1	0.53	29	E53.N76-104H11	8 / FB4



E53 H/E55

DC

1500...5000V DC



C_N (μ F)	U_r (V)	R_s (m Ω)	R_{th} (K/W)	I_{max} (A)	\hat{I} (kA)	I_s (kA)	L_e (nH)	$D_1 \times L_1$ (mm)	Design Maßbild	m (kg)	L/K (mm)	order no. Bestell-Nr.	pcs_Stk / Box
U_N 1500V DC		U_s 2250V			U_r (see chart)			U_{BB} 2250V DC					
37.5	300	1.2	6.1	60	1.4	4	30	85 × 51	H1	0.36	29/33	E53.N51-383H11	8 / FB6
50	300	1.5	4.8	60	1.4	4.2	35	85 × 64	H1	0.45	29/33	E53.N64-503H10	8 / FB4
75	300	2	4.1	60	1.4	4.2	40	85 × 76	H1	0.53	29	E53.N76-753H11	8 / FB4
U_N 1800V DC		U_s 2700V			U_r (see chart)			U_{BB} 2700V DC					
22	600	1.5	6.3	40	1.6	4.8	15	75 × 56	T2	0.33	111	E55.M56-223T20	10 / FB2
30	400	0.73	6.1	60	1.3	3.9	30	85 × 51	H1	0.36	29/33	E53.N51-303H11	8 / FB6
40	400	1.6	4.8	60	1.3	3.9	35	85 × 64	H1	0.45	29/33	E53.N64-403H10	8 / FB4
60	400	2.1	4.1	50	1.3	3.9	40	85 × 76	H1	0.53	29	E53.N76-603H11	8 / FB4
80	600	0.45	4.1	100	5.2	15.6	15	115 × 56	T2	0.77	151	E55.R56-803T20	12 / FB9
U_N 2000V DC		U_s 3000V			U_r (see chart)			U_{BB} 3000V DC					
13	400	1.6	6.1	55	0.64	1.92	30	85 × 51	H1	0.36	29/33	E53.N51-133H10	8 / FB6
30	400	1.3	4.8	55	1.1	3.3	35	85 × 64	H1	0.45	29/33	E53.N64-303H10	8 / FB4
43	400	1.8	4.1	50	1	3	40	85 × 76	H1	0.53	29	E53.N76-433H10	8 / FB4
50	650	0.55	4.1	100	4.1	12.3	15	115 × 56	T2	0.77	151	E55.R56-503T20	12 / FB9
U_N 2200V DC		U_s 3300V			U_r (see chart)			U_{BB} 3300V DC					
24.5	600	1.4	4.8	55	0.99	2.97	35	85 × 64	H1	0.45	29/33	E53.N64-253H10	8 / FB4
35	600	1.9	4.1	50	0.94	2.82	40	85 × 76	H1	0.53	29	E53.N76-353H10	8 / FB4
U_N 2400V DC		U_s 3600V			U_r (see chart)			U_{BB} 3600V DC					
30	700	0.34	4.1	100	3	10	15	115 × 56	T2	0.77	151	E55.R56-303T20	12 / FB9
U_N 2800V DC		U_s 4200V			U_r (see chart)			U_{BB} 4200V DC					
18	800	0.6	4.5	90	4.5	13.5	15	105 × 56	T2	0.64	14	E55.Q56-183T20	10 / FB2
U_N 3200V DC		U_s 4800V			U_r (see chart)			U_{BB} 4800V DC					
10	1000	0.71	4.1	100	2.8	8.4	15	115 × 56	T2	0.77	151	E55.R56-103T20	12 / FB9
U_N 5000V DC		U_s 7500V			U_r (see chart)			U_{BB} 7500V DC					
10	1500	1.3	2.3	100	1.9	6	15	115 × 100	T2	1.37	195	E55.R10-103T20	6 / FB8

Other values and dimensions available on request

Andere Werte und Abmessungen auf Anfrage erhältlich



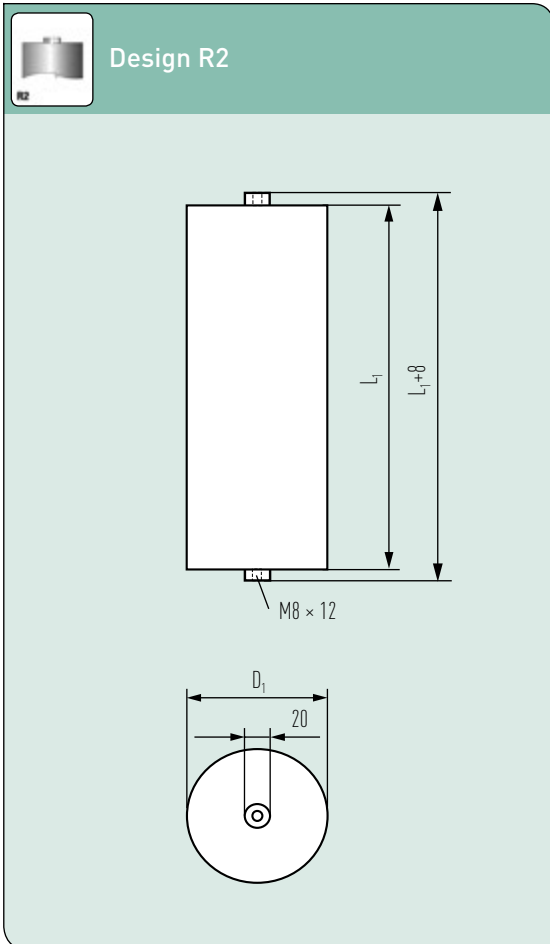
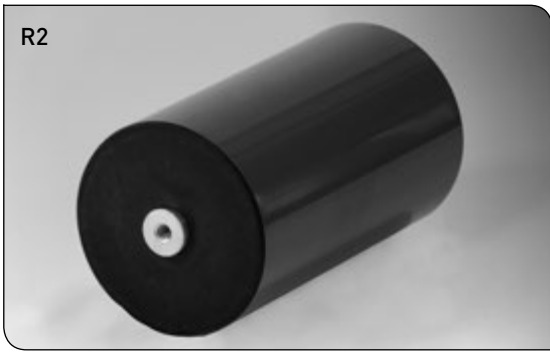

CAPACITORS WITH A CAN DIAMETER OF 64, 90, 116, 140 mm

- Can material plastic can, filled with solid PUR resin
- Terminals axial thread M8 × 12 mm
- I_{max} (Terminals) 100 A
- Degree of protection IP 00
- K/L ($L_1 + D_1 - 20$ mm)
- Humidity class F

KONDENSATOREN MIT GEHÄUSEDURCHMESSER 64, 90, 116, 140 mm

- Gehäusematerial Kunststoff, gefüllt mit ausgehärtetem Polyurethanharz
- Anschlüsse axiales Schraubgewinde M8 × 12 mm
- I_{max} (Anschlüsse) 100 A
- Schutzgrad IP 00
- K/L ($L_1 + D_1 - 20$ mm)
- Feuchteklasse F



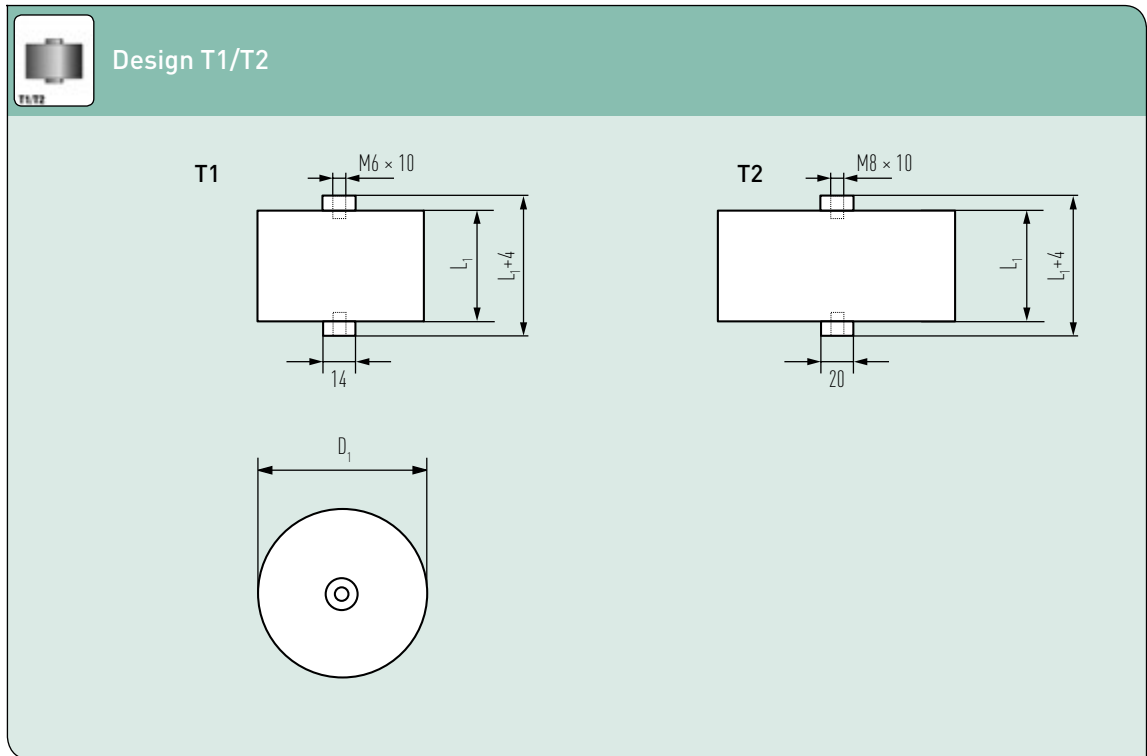
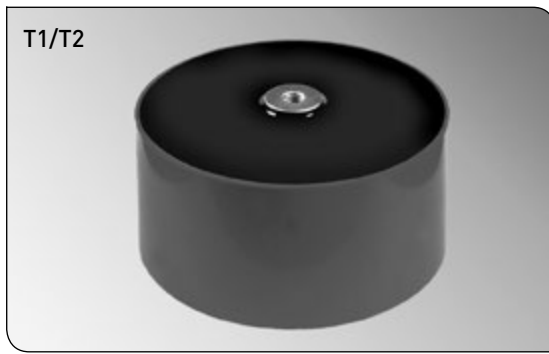

T1 CAPACITORS WITH A CAN DIAMETER OF 55...60 mm

T2 CAPACITORS WITH A CAN DIAMETER OF 75...115 mm

Can material plastic can, filled with solid PUR resin

Terminals axial thread

T1 M6 × 10 mm

T2 M8 × 10 mm

I_{max} (Terminals)

T1 60 A

T2 100 A

Degree of protection IP 00

K/L see data charts

Humidity class 6

T1 KONDENSATOREN MIT GEHÄUSEDURCHMESSER 55...60 mm

T2 KONDENSATOREN MIT GEHÄUSEDURCHMESSER 75...115 mm

Gehäusematerial Kunststoff, gefüllt mit ausgehärtetem Polyurethanharz

Anschlüsse axiales Schraubgewinde

T1 M6 × 10 mm

T2 M8 × 10 mm

I_{max} (Anschlüsse)

T1 60 A

T2 100 A

Schutzgrad IP 00

K/L siehe Datentabellen

Feuchteklasse 6



H1



Design H1

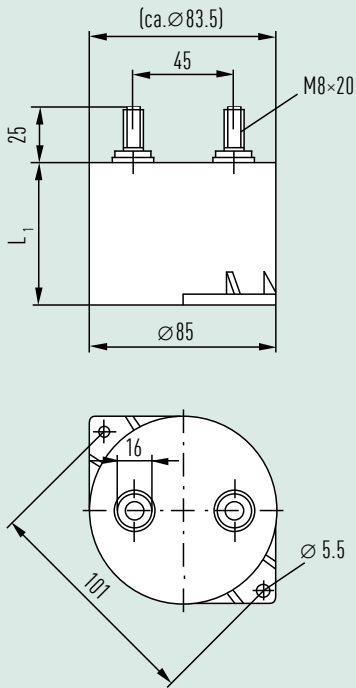

H1 CAPACITORS WITH A CAN DIAMETER OF 85 mm

- Can material plastic can, filled with solid PUR resin
- Fixing lateral mounting brackets
- Terminals threaded studs M8 x 20 mm
- I_{max} (Terminals) 100 A
- Degree of protection IP 00
- K/L see data charts
- Humidity class F

H1 KONDENSATOREN MIT GEHÄUSEDURCHMESSER 85 mm

- Gehäusematerial Kunststoff, gefüllt mit ausgehärtetem Polyurethanharz
- Befestigung seitliche Montagelaschen
- Anschlüsse Gewindebolzen M8 x 20 mm
- I_{max} (Anschlüsse) 100 A
- Schutzgrad IP 00
- K/L siehe Datentabellen
- Feuchteklasse F



Important Remarks

Safety

ELECTRONICON will not indemnify or be responsible for any kind of damages to persons or property due to the improper application of any capacitors purchased from ELECTRONICON or its distributors.

The capacitors should only be used for the application intended.

Mind that electrical or mechanical misapplication of capacitors can become hazardous. Misapplied capacitors can explode or catch fire and cause bodily injury or property damage due to the expulsion of material or metal fragments.

Please consult the detailed instructions for mounting and application stated in our brochure „Application Notes“ and on the ELECTRONICON website.

If in doubt about how to connect, operate, or discharge a capacitor, consult ELECTRONICON engineering.

Mounting And Cooling

The useful life of a capacitor may be reduced dramatically if exposed to excessive heat. Typically an increase in the ambient temperature of 7°C will halve the expected life of the capacitor. Make sure to obey the permitted operating temperatures.

To avoid overheating the capacitors must be allowed to cool unhindered and should be shielded from external heat sources. We recommend forced ventilation for all applications with detuning reactors.

Give at least 20mm clearance between the capacitors for natural or forced ventilation, and do not place them directly above or next to heat sources such as detuning or tuning reactors, bus bars, etc.

Protection against Overvoltages And Short Circuits: Self-Healing Dielectric

All dielectric structures used in our power capacitors are „selfhealing“: In the event of a voltage breakdown the metal layers around the breakdown channel are evaporated by the temperature of the electric arc that forms between the electrodes. They are removed within a few microseconds and pushed apart by the pressure generated in the centre of the breakdown spot.

An insulation area is formed which is reliably resistive and voltage proof for all operating requirements of the capacitor. The capacitor remains fully functional during and after the breakdown.

For voltages within the permitted testing and operating limits the capacitors are short-circuit- and overvoltage-proof. They are also proof against external short circuits as far as the resulting surge discharges do not exceed the specified surge current limits.

Wichtige Hinweise

Sicherheit

ELECTRONICON übernimmt keine Verantwortung oder Haftung für jegliche Schäden an Personen oder Eigentum, welche aus der unsachgemäßen Anwendung von bei ELECTRONICON oder seinen Distributoren erworbenen Kondensatoren herrühren.

Die Kondensatoren dürfen ausschließlich für ihren Bestimmungszweck verwendet werden.

Beachten Sie, daß ein elektrisch oder mechanisch fehlerhafter Einsatz von Kondensatoren gefährlich sein kann. Falsch eingesetzte Kondensatoren können explodieren oder Feuer fangen und infolge austretender Materialien bzw. Metallteile gesundheitliche und materielle Schäden verursachen.

Bitte konsultieren Sie die detaillierten Anweisungen in unserer Broschüre „Anwendungshinweise“ sowie auf der Webseite von ELECTRONICON.

Bitte konsultieren Sie das Fachpersonal von ELECTRONICON oder seiner Distributoren bei allen Fragen bezüglich des Anschlusses, der Verwendung oder der Entladung von Kondensatoren.

Montage und Kühlung

Die Lebensdauer eines Kondensators kann durch übermäßige Wärmeeinwirkung erheblich verringert werden. Im allgemeinen führt eine Erhöhung der Umgebungstemperatur um 7°C zu einer Verringerung der Lebensdauer des Kondensators um 50 %. Halten Sie die zugelassenen Betriebstemperaturen ein.

Um Überhitzung zu vermeiden, muß gewährleistet sein, daß die Kondensatoren auftretende Verlustwärme ungehindert abführen können und vor fremden Wärmequellen abgeschirmt werden. Insbesondere bei verdrosselten Anlagen ist in jedem Falle eine Zwangslüftung zu empfehlen. Zwischen den und um die Kondensatoren herum sollten mindestens 20mm Platz für natürliche oder Zwangslüftung belassen werden. Bringen Sie den Kondensator nie direkt neben oder über Wärmequellen, wie Drosseln u. ä. an.

Schutz gegen Überspannungen und Kurzschlüsse: Selbstheilendes Dielektrikum

Alle in unseren Leistungskondensatoren eingesetzten dielektrischen Strukturen sind selbstheilend. Im Falle eines Kurzschlusses (Spannungsdurchschlag) verdampfen die Metallbeläge um den Durchschlagspunkt herum aufgrund der Temperatur des Lichtbogens, der sich zwischen den Elektroden bildet. Innerhalb weniger Mikrosekunden wird der Metaldampf durch den beim Durchschlag entstehenden Überdruck vom Zentrum des Durchschlages weggedrückt. Aus diese Weise bildet sich eine belagfreie Zone rings um den Durchschlagspunkt, wodurch dieser vollständig isoliert wird. Der Kondensator bleibt während und nach dem Durchschlag voll funktionsfähig.

Für Spannungen innerhalb der zugelassenen Test- und Betriebsbedingungen sind die Kondensatoren kurzschluss- und überspannungssicher. Sie sind außerdem sicher gegen äußere Kurzschlüsse, sofern bei den dabei entstehenden Stoßentladungen die zugelassenen Stoßströme nicht überschritten werden.

Failure Rate

The failure probability of a component is a statistical value which is described by a log-normal distribution:

$$N = N_0 \times e^{-\lambda t}$$

Ausfallrate

Die Ausfallwahrscheinlichkeit eines Bauelements ist eine statistische Größe, die mit Hilfe einer Normalverteilung beschrieben wird. Es gilt:

N = number of functional components after period t
Anzahl der nach der Zeit t intakten Bauelemente
N₀ = total number of components at time t = 0
Gesamtzahl der Bauelemente zum Zeitpunkt t = 0
λ = failure rate Ausfallrate

λ is the failure rate, which alternatively is also stated as the so-called FIT-rate (FIT = Failures In Time = λ x 10⁹).

The failure rate is very closely linked with operating temperature and operating voltage of the capacitor. The FIT rates stated in this catalogue are related to the capacitors' rated voltage and a dielectric temperature (= HOTSPOT temperature) of 70°C.

The simultaneous operation of capacitors at highest permissible voltage and operating temperature should be avoided; otherwise, failure rates may increase beyond reasonable technical reliability.

The standard reference period for the failure rate statement is 100 000 hours.

Please note that FIT rates can be altered or improved by technical adjustments. Please contact us for details.

The diagrams on the following page demonstrate the correlation between FIT rate, operating voltages and operating temperatures.

Dabei ist λ die Ausfallrate, die alternativ auch als FIT -Rate angegeben wird (FIT = λ x 10⁹)

Die Ausfallrate ist stark abhängig von der Temperatur und der Betriebsfeldstärke. Die FIT-Raten im Katalogsortiment beziehen sich auf 70°C Dielektrikumtemperatur (=Hotspot-Temperatur) und die Nennspannung des Kondensators.

Der Betrieb von Kondensatoren mit der höchsten zulässigen Spannung und der höchsten zulässigen Betriebstemperatur sollte vermieden werden, andernfalls können die Ausfallraten so hoch werden, dass keine technisch sinnvollen Zuverlässigkeiten mehr gewährleistet sind.

Der Wert für die Ausfallrate bezieht sich auf einen Referenzzeitraum von 100.000h.

Bitte beachten Sie, daß FIT-Raten durch technische Anpassung der Kondensatoren beeinflusst und verbessert werden können. Auskünfte hierzu erteilen wir auf Anfrage.

Die Kurvendiagramme auf der folgenden Seite machen den Zusammenhang von FIT-Rate, Betriebsspannung und Betriebstemperatur deutlich.





50 FIT

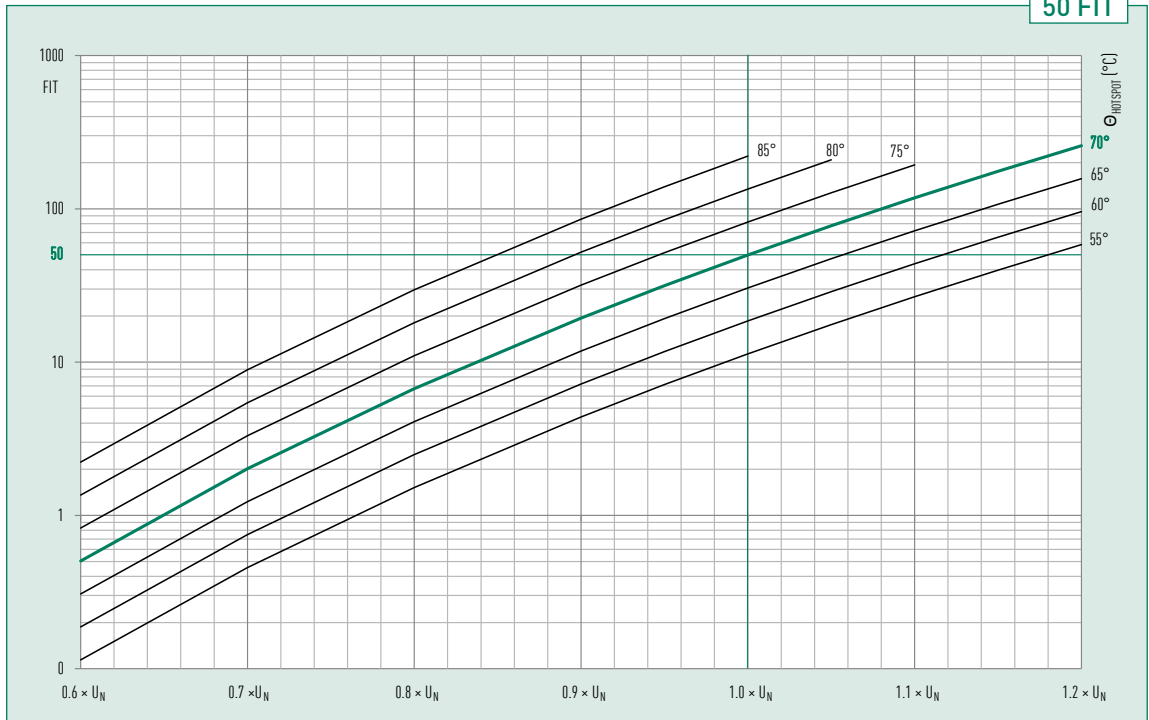

100 FIT

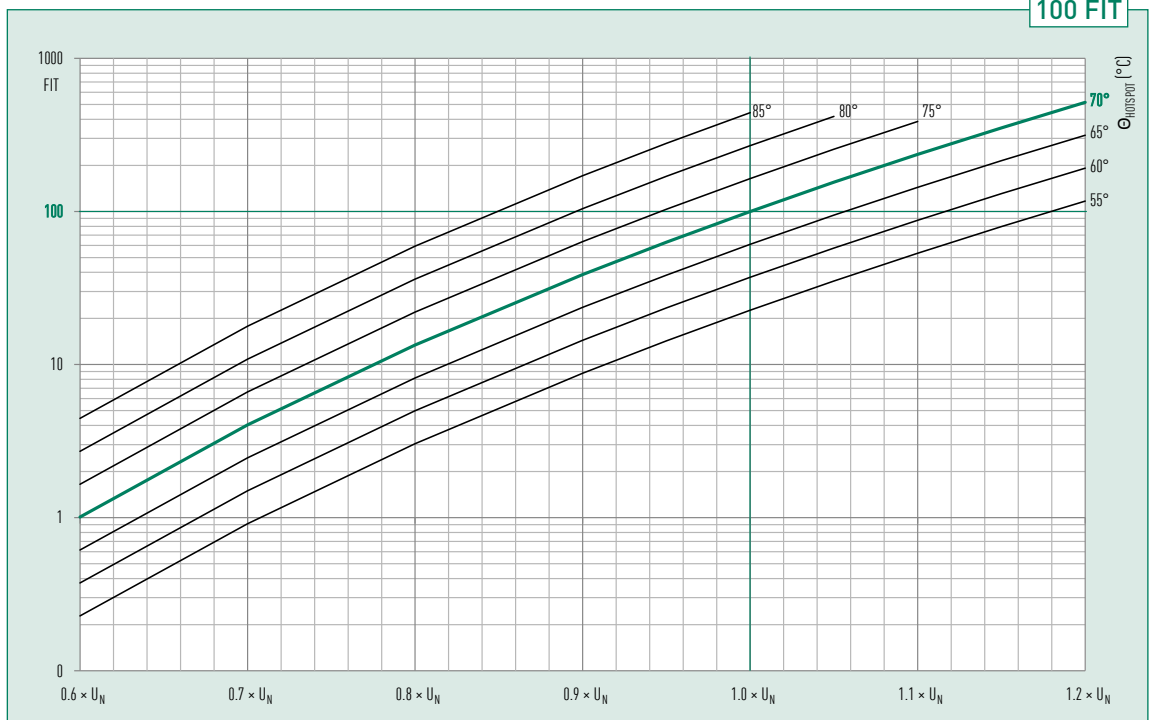

2 Year Limited Warranty

All our products are designed, manufactured, and tested with the highest care and workmanship. The satisfaction of our customers is our highest goal. We therefore warrant remedying any defect in the goods resulting from faulty design, materials or workmanship, which appears within 2 years from the date of sale.

This warranty does not cover defects due to improper use of the goods or operation at conditions exceeding the rated values stated in the catalogue or special data sheet. Nor does it cover defects due to faulty maintenance or incorrect installation, alterations or faulty repairs undertaken by the Buyer. Finally the warranty does not cover normal wear and tear or deterioration.

See our „General Conditions“ for details on Warranty and Product liability.

Find more information and detailed instructions in our „Application Notes“ and on www.electronicon.com



2 Jahre Gewährleistung

Alle unsere Erzeugnisse werden mit höchster Sorgfalt und Fachkenntnis entwickelt, hergestellt und geprüft. Die Zufriedenheit unserer Kunden ist unser höchstes Ziel. Wir verpflichten uns daher, jeden innerhalb von 2 Jahren ab Verkaufsdatum auftretenden Mangel an unseren Erzeugnissen zu beseitigen, welcher aus Fehlern in Design, Material oder Herstellung herrührt.

Diese Gewährleistung erstreckt sich nicht auf Defekte, welche auf unsachgemäße Anwendung oder Betrieb jenseits der nach Katalog oder speziellem Datenblatt zulässigen Einsatzbedingungen zurückzuführen sind. Sie erfasst ebensowenig Schäden, welche aus fehlerhafter Wartung, unsachgemäßer Montage, Änderungen oder unsachgemäßen Reparaturen durch den Käufer bzw. Anwender resultieren. Schließlich betrifft diese Gewährleistung auch nicht normale Abnutzung und Verschleiß.

Siehe unsere „Allgemeinen Geschäftsbedingungen“ für Details zu Gewährleistung und Produkthaftung.

Mehr Informationen und ausführliche Anweisungen finden Sie in unseren „Anwendungshinweisen“ und unter www.electronicon.com



NOTES
NOTIZEN

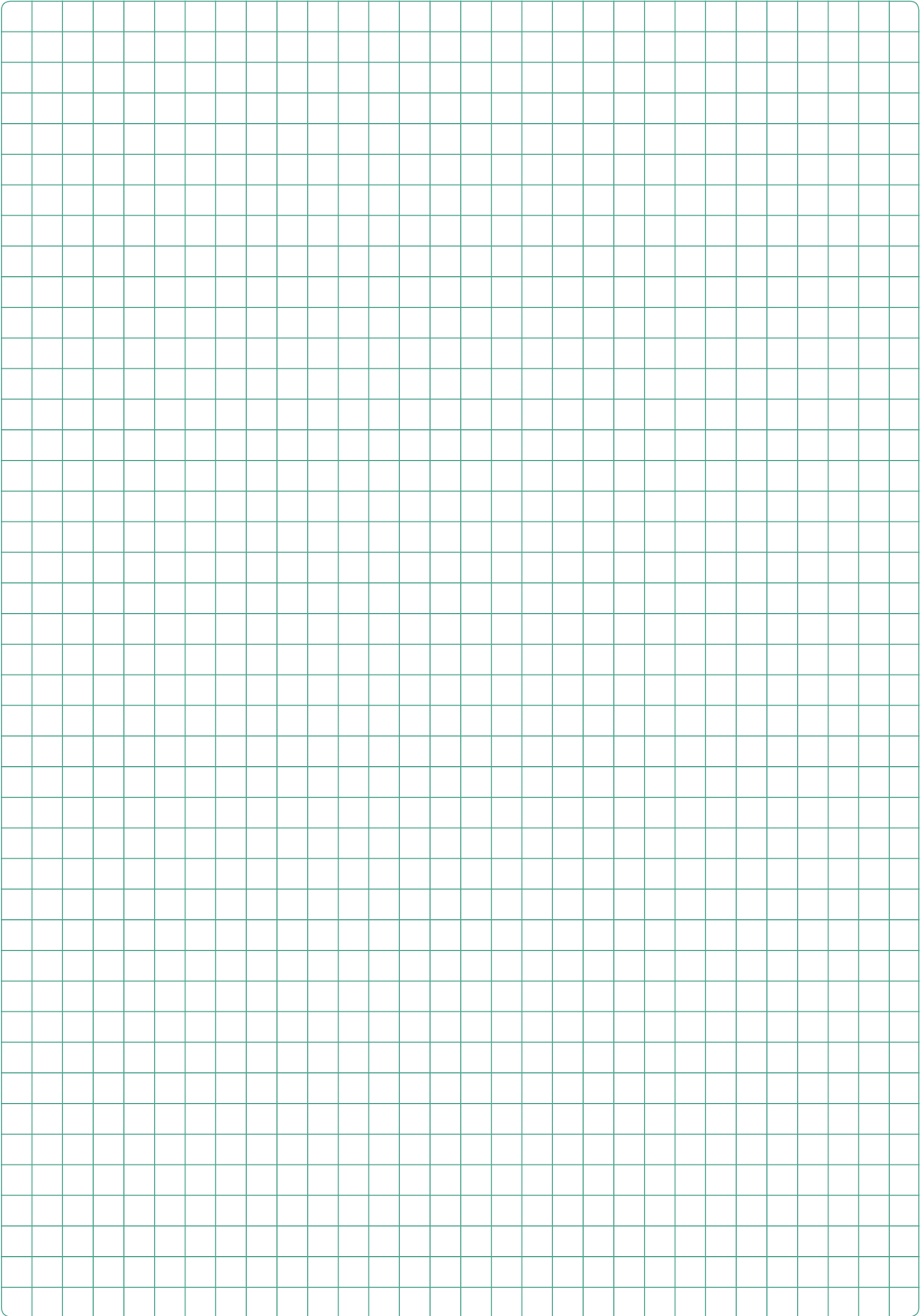

NOTES_NOTIZEN



CAPACITORS FOR APPLICATIONS IN POWER ELECTRONICS

www.electronicon.com



E51/E53/E55
AC/DC FILM CAPACITORS



HIGH VOLTAGES, HEAVY CURRENTS, AND LOW INDUCTANCE

ELECTRONICON
always in charge

www.electronicon.com



E57/E59/SR17™ AC AND DC CAPACITORS
WITH LARGE CAPACITANCES



STANDARD OR SPECIAL – YOUR CHOICE

ELECTRONICON
always in charge

www.electronicon.com Issue 1/2018



for latest edition
and updates check
www.powercapacitors.info

PK16™ AND E61
– HIGH DENSITY DC FILM
CAPACITORS



THE IDEAL CHOICE FOR YOUR DC LINK

ELECTRONICON
always in charge

www.electronicon.com



E62 AND E64
HEAVY DUTY AC CAPACITORS



THE PERFECT CHOICE FOR YOUR AC/DC APPLICATION

ELECTRONICON
always in charge

www.electronicon.com



E62-3ph AND 3HF
HEAVY DUTY THREE PHASE AC FILTER CAPACITORS



HIGH-END FOR THE HEART OF YOUR AC FILTER

ELECTRONICON
always in charge

www.electronicon.com



PEC APPLICATION NOTES / ANWENDUNGSHINWEISE



ELECTRONICON
always in charge

always in charge

EXCELLENT EXPERIENCE IN CAPACITOR MAKING FOR OVER 75 YEARS

Gera has been a centre of capacitor making since 1938. ELECTRONICON Kondensatoren GmbH which emerged from previous RFT/VEB ELEKTRONIK Gera in 1992, has become one of Europe's leading capacitor manufacturers supplying customers worldwide and being an open and competent partner for manufacturers and users of power factor correction equipment, for many manufacturers of drives, power electronics, home appliances, and for the lighting industry. Regular investments in advanced and environmentally sound technologies guarantee the highest levels in manufacture and quality to modern standards which are approved and monitored by leading certification authorities.



In today's globalised competition, we distinguish ourselves by

- Absolute reliability and safety of our products
- Close co-operation between manufacturer and client to meet both technical and commercial requirements
- Improvement and development of our technical expertise in capacitor design and manufacture, as well as film coating, with special attention paid to the MKPg-technology
- Early identification and incorporation of new trends and methods in the manufacturing of capacitors
- Flexibility and punctual fulfilment of our commercial obligations

Our experienced development engineers are competent and responsible for both implementing the latest technical trends applicable to our products and ensuring that our products adapt to the challenges of traditional and new markets.

The close and intense co-operation between the departments of Marketing & Sales, Research & Development, and Production has become the keystone of our success. ELECTRONICON is continually striving to establish a similarly close and interactive relationship with its distributors and direct clients both in home and overseas markets, to become not just one out of many suppliers, but your preferred partner for ideas and solutions.

ELECTRONICON®

Germany • 07549 Gera • Keplerstrasse 2
Fon +49 365 / 734 61 00 • Fax +49 365 / 734 61 10
E-Mail: sales@electronicon.com, www.electronicon.com

