



## KEY COMPONENTS FOR POWER FACTOR CORRECTION IN 60Hz MAINS



for latest edition  
and updates check  
[www.powercapacitors.info](http://www.powercapacitors.info)



FACTORY MATCHED  
TO OPERATE IN PERFECT HARMONY

**ELECTRONICON**<sup>®</sup>  
always in charge

CHECK OUR SPECIAL CATALOGUE

MSD™ FKD-MV™ DSC™

FOR POWER FACTOR CORRECTION IN MEDIUM VOLTAGE MAINS:

[www.electronicon.com](http://www.electronicon.com)



MSD™ FKD-MV™ DSC™

MEDIUM VOLTAGE CAPACITORS  
AND REACTORS



THE ECO-FRIENDLY ALTERNATIVE

**ELECTRONICON**<sup>®</sup>  
always in charge

# CAPACITORS AND OTHER KEY COMPONENTS FOR POWER FACTOR CORRECTION IN 60Hz MAINS



ELECTRONICON KONDENSATOREN GMBH GERA • GERMANY

# CONTENTS

<b>INTRODUCTION</b>	<b>6</b>
Basics of Power Factor Correction – Calculation of Required Capacitor Power and Common Methods – Influence of Harmonics, Harmonic Filtering – Capacitors in High Frequency Filters	
<b>OUR RANGE OF FACTORY MATCHED KEY COMPONENTS</b>	<b>13</b>
<b>POWER CAPACITORS</b>	<b>14</b>
<b>INTERNAL CONSTRUCTION</b>	<b>16</b>
Dielectric – Impregnants - MKPg 265	
<b>SAFE OPERATION</b>	<b>17</b>
Self-Healing Dielectric – Protection Against Accidental Contact – Protection Against Overload	
<b>TERMINATION DESIGNS</b>	<b>19</b>
CAPAGRIP™ - MKP(D)	
<b>DEFINITIONS AND SELECTION CRITERIA</b>	<b>23</b>
Voltage Ratings – Test Voltages – Rated Power – Current Ratings – Temperature Categories – Lifetime Statements	
<b>GENERAL TECHNICAL DATA</b>	<b>25</b>
<b>DATA CHARTS MKPg 265 3PH GAS-FILLED</b>	
230 ... 280 V	26
380 ... 480 V	27
400 ... 525 V	28
440 ... 525 V	29
480 ... 800 V	30
<b>DATA CHARTS MKPg 266 3PH OIL-FILLED</b>	
480 ... 800 V	31
<b>MOUNTING AND OPERATING INSTRUCTIONS</b>	<b>32</b>
Mounting Position – Mounting Location/Cooling – Vibration Stress – Connection – Selection of Cables – Termination Torques – Discharge – Earthing – Environment – Disposal	

# CONTENTS

<b>SWITCHING AND DISCHARGING CAPACITORS</b>	<b>36</b>
CAPACITOR CONTACTORS	38
1301A Series	38
THYRISTOR SWITCHES	40
CONDENSOTRONIC CT 2000	41
TS12-2	43
DISCHARGE DEVICES & ACCESSORY PARTS	45
RESISTOR MODULES	45
DISCHARGE REACTOR EL-Dr	48
PROTECTIVE BLANK	49
<b>DETUNING REACTORS</b>	<b>50</b>
DEFINITIONS AND SELECTION CRITERIA	53
Rated Inductance – Rated Voltage – Capacitor Voltage – Detuning Factor – Series Resonance Frequency – Rated Reactor Power – Dissipation Power – Rated Current – RMS Current – Maximum Current Rating – Ambient Operating Conditions – Insulation Class – Temperature Switch	
GENERAL TECHNICAL DATA	57
DIMENSION DRAWINGS	58
DATA CHARTS <a href="#">FK-DR</a>	
non-adapted rating (D) 5.67 % / 7 %	62
non-adapted rating (D) 5.67 % / 6 % / 7 %	63
adapted rating (DIa) 5.67 % / 6 % / 7 %	64
<b>POWER FACTOR CONTROLLERS</b>	<b>66</b>
PFR-X/PFR-M	
<b>ANNEX</b>	<b>71</b>
Safety Recommendations – Certificates – Packing Details	

# INTRODUCTION

## BASICS OF POWER FACTOR CORRECTION

Under normal operating conditions certain electrical loads (e.g. induction motors, welding equipment, arc furnaces and fluorescent lighting) draw not only active power from the supply, but also inductive reactive power (kvar). This reactive power is necessary for the equipment to operate correctly but could be interpreted as an undesirable burden on the supply. The power factor of a load is defined as the ratio of active power to apparent power, i.e. kW : kVA and is referred to as  $\cos\phi$ . The closer  $\cos\phi$  is to unity, the less reactive power is drawn from the supply.

A capacitive reactive power resulting from the connection of a correctly sized capacitor can compensate for the inductive reactive power required by the electrical load. This ensures a reduction in the reactive power drawn from the supply and is called Power Factor Correction.

## CALCULATION OF REQUIRED CAPACITOR POWER

The reactive power which is necessary to achieve a desired power factor is calculated by the formula:  $Q_c = P \cdot F$

$Q_c$  ... reactive power of the required power capacitor

$P$  ... active power of the load to be corrected

$F$  ... conversion factor acc. to chart 1

original power factor $\cos\phi_1$	conversion factor F for a target power factor $\cos\phi_2$									
	0.70	0.75	0.80	0.85	0.90	0.92	0.94	0.96	0.98	1.00
0.20	3.879	4.017	4.149	4.279	4.415	4.473	4.536	4.607	4.696	4.899
0.25	2.853	2.991	3.123	3.253	3.389	3.447	3.510	3.581	3.670	3.873
0.30	2.160	2.298	2.430	2.560	2.695	2.754	2.817	2.888	2.977	3.180
0.35	1.656	1.795	1.926	2.057	2.192	2.250	2.313	2.385	2.473	2.676
0.40	1.271	1.409	1.541	1.672	1.807	1.865	1.928	2.000	2.088	2.291
0.45	0.964	1.103	1.235	1.365	1.500	1.559	1.622	1.693	1.781	1.985
0.50	0.712	0.85	0.982	1.112	1.248	1.306	1.369	1.440	1.529	1.732
0.55	0.498	0.637	0.768	0.899	1.034	1.092	1.156	1.227	1.315	1.518
0.60	0.313	0.451	0.583	0.714	0.849	0.907	0.97	1.042	1.130	1.333
0.65	0.149	0.287	0.419	0.549	0.685	0.743	0.806	0.877	0.966	1.169
0.70		0.138	0.27	0.4	0.536	0.594	0.657	0.729	0.817	1.020
0.75			0.132	0.262	0.398	0.456	0.519	0.59	0.679	0.882
0.80				0.13	0.266	0.324	0.387	0.458	0.547	0.75
0.85					0.135	0.194	0.257	0.328	0.417	0.62
0.90						0.058	0.121	0.193	0.281	0.484
0.95								0.037	0.126	0.329

chart 1

# INTRODUCTION

## A. Calculation based on the consumption data

- consumption of active energy:  $E_w = 300.000 \text{ kWh}$
- consumption of reactive energy:  $E_b = 400.000 \text{ kvarh}$
- number of working hours:  $t = 600 \text{ h}$

1) Calculation of average active power P

$$P = \frac{E_w}{t} = \frac{300.000 \text{ kWh}}{600 \text{ h}} = 500 \text{ kW}$$

2) Calculation of initial power factor  $\cos\varphi_1$

$$\cos\varphi_1 = \frac{1}{\sqrt{\left(\frac{E_b}{E_w}\right)^2 + 1}} = \frac{1}{\sqrt{\left(\frac{400.000 \text{ kvarh}}{300.000 \text{ kWh}}\right)^2 + 1}} = 0.6$$

3) From chart 1, we read the factor 1.13 for the improvement of the power factor from 0.6 to 0.98.

4) Calculation of required capacitor power

$$Q_c = 500 \text{ kW} \cdot 1.13 = 565 \text{ kvar}$$

## B. Calculation based on the Energy Bill

- reactive power tariff:  $T/\text{kvarh}$
- monthly costs for reactive energy:  $C$
- number of working hours:  $h$

Calculation of required capacitor power for  $\cos\varphi = 1$

$$Q_c = \frac{C}{h \cdot \frac{T}{\text{kvarh}}}$$



Example



# INTRODUCTION

## COMMON METHODS OF POWER FACTOR CORRECTION

**SINGLE OR FIXED PFC**, compensating for the reactive power of individual inductive loads at the point of connection so reducing the load in the connecting cables (typical for single, permanently operated loads with a constant power),

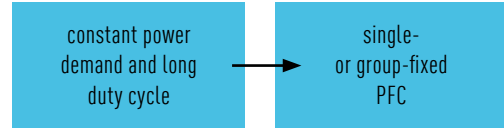

**GROUP PFC** - connecting one fixed capacitor to a group of simultaneously operated inductive loads (e.g. group of motors, discharge lamps),

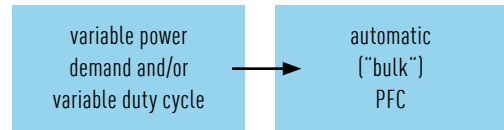

**BULK PFC**, typical for large electrical systems with fluctuating load where it is common to connect a number of capacitors to a main power distribution station or substation. The capacitors are controlled by a microprocessor based relay which continuously monitors the reactive power demand on the supply. The relay connects or disconnects the capacitors to compensate for the actual reactive power of the total load and to reduce the overall demand on the supply.

A typical power factor correction system would incorporate a number of capacitor sections determined by the characteristics and the reactive power requirements of the installation under consideration. Sections of 12.5 kvar, 25 kvar, and 50 kvar are usually employed. Larger stages (e.g. 100 kvar and above) are best achieved by cascading a number of smaller sections. This has the beneficial effect of reducing fluctuations in the mains caused by the inrush currents to the capacitors and minimizes supply disturbances. Where harmonic distortion is of concern, appropriate systems are supplied incorporating detuning reactors.

## INFLUENCE OF HARMONICS, HARMONIC FILTERING



Developments in modern semiconductor technology have led to a significant increase in the number of thyristor- and inverter-fed loads. Unfortunately these non-linear loads have undesirable effects on the incoming AC supply, drawing appreciable inductive reactive power and a non-sinewave current. The supply system needs to be kept free of this harmonic distortion to prevent equipment malfunction.

A typical inverter current is composed of a mixture of sinewave currents; a fundamental component at the supply frequency and a number of harmonics whose frequencies are integer multiples of the line frequency (in three phase mains most of all the 5th, 7th, and 11th harmonic). The harmonics lead to a higher capacitor current, because the reactive resistance of a capacitor reduces with rising frequency. The rising capacitor current can be accommodated by constructional improvements in the manufacture of the capacitor. However a resonating circuit between the power factor correction capacitors, the inductance of the feeding transformer and/or the mains may occur. If the frequency of such a resonating circuit is close enough to a harmonic frequency, the resulting circuit amplifies the oscillation and leads to immense over-currents and over-voltages.

**Harmonic distortion of an AC supply can result in any or all of the following:**

- Premature failure of capacitors.
- Nuisance tripping of circuit breakers and other protective devices.
- Failure or maloperation of computers, motor drives, lighting circuits and other sensitive loads

**Typical non-linear loads (generating harmonics)**

- converters, rectifiers, inverters, choppers
- thyristor controls, three-phase controllers
- electronic valves
- phase controls
- UPS units (inverter technology)
- discharge lamps with magnetic ballasts



# INTRODUCTION

## WHEN IS IT NECESSARY TO INSTALL A DETUNED PFC SYSTEM?

The installation of detuned (reactor-connected) capacitors is designed to force the resonant frequency of the network below the frequency of the lowest harmonic present, thereby ensuring no resonant circuit and, by implication, no amplification of harmonic currents. Such an installation also has a partial filtering effect, reducing the level of voltage distortion on the supply, and is recommended for all cases where the share of harmonic-generating loads ("non-linear loads") is more than 10% of the rated transformer power. The resonance frequency of a detuned capacitor is always below the frequency of the lowest harmonic present. A close-tuned filter circuit however is tuned to a certain harmonic frequency and presents a very low impedance to the individual harmonic current, diverting the majority of the current into the filter bank rather than the supply.



Detuned capacitors can in general be operated in any mains. In any case, they are a safer choice than non-detuned capacitors and future-proof under the conditions of more and more deteriorating power quality in modern mains.

**Attention: Non-detuned and detuned capacitors must never be combined together.**



We strongly advise to conduct a comprehensive mains analysis, including measurement of the harmonic content, before designing and installing your power factor correction equipment. In cases, however, where such analysis is not possible, cautious and conservative assessment of the situation to be expected shall be made by means of the general rules in chart 3.

A detuned PFC system is also necessary

- if one or more harmonic voltages in the MV mains are > 2 %, and/or
- if certain audio frequency control signals are used (see page 10)

$S_{OS} : S_T$	Detuning
0 % ... 100 %	non-detuned
> 10 % ... 50 %	detuned
> 40 % ... 100 %	detailed calculation needed, installation of filter circuit if necessary

Abbreviations  
 $S_{OS}$  ... power of harmonic generating („non-linear“) loads in the own network  
 $S_T$  ... rated transformer power or connection power

chart 3

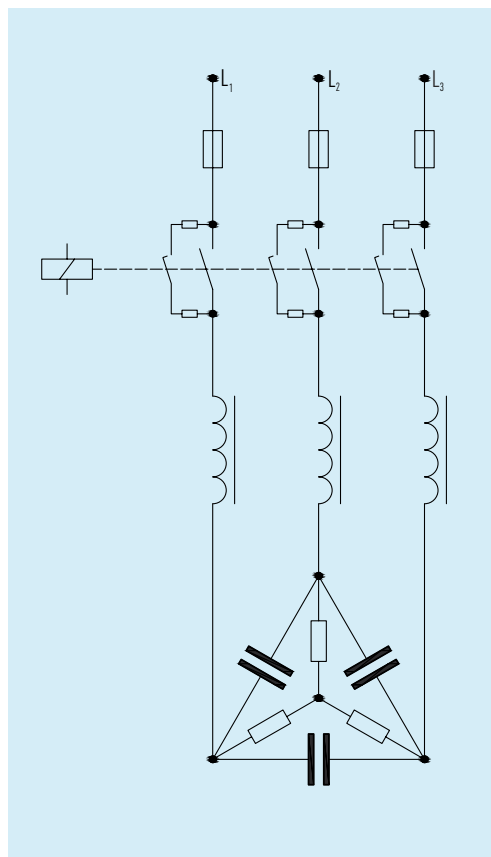

Installation of detuned (reactor-connected) capacitors

pic. 1

# INTRODUCTION

## DOES THE MV MAINS CONTAIN AUDIO FREQUENCY CONTROL SIGNALS?

Some energy supply companies use higher-frequency signals in their medium voltage mains for the transmission of control pulses and data. These so-called "audio frequency signals" ranging typically from 160 to 1350 Hz may become absorbed or distorted by, or cause resonance problems with capacitor installations. Such problems may be prevented by the selection of proper detuning reactors.

Capacitor/PFC system	audio frequency	reactive power	activity
non-detuned	< 300 Hz	$Q_c \leq 35\% \text{ of } S_T$ $Q_c > 35\% \text{ of } S_T$	no specific activity consult your power supply company and conduct mains analysis
	> 300 Hz	$Q_c \leq 10 \text{ kvar}$ $Q_c > 10 \text{ kvar}$	no specific activity consult your power supply company and consider special PFC system
detuned	< 300 Hz	no restrictions	consult your power supply company and consider special PFC system
	300 Hz ... 420 Hz	no restrictions	detuning factor $\geq 7\%$
	> 420 Hz	no restrictions	detuning factor $\geq 5\%$

chart 4

# INTRODUCTION

## OPERATION OF CAPACITORS IN HIGH-FREQUENCY-FILTERS OR WITH A VERY HIGH SHARE OF LF OR HF HARMONICS

Capacitors which are operated in filters or other systems with a very high share of harmonic distortion, or with harmonics of high frequencies, must be especially selected and prepared for the specific requirements of such applications.

We offer special single and three phase capacitors that are optimized for the operation under such circumstances in our following ranges:

- 280 MKP-UHD: three phase Ultra Heavy Duty capacitors for demanding operating conditions in power factor correction (such as high harmonic content and high operating temperatures)
- E62-3ph: three phase capacitors for filters with harmonic frequencies of up to 1.3 kHz
- E62-3HF: three phase capacitors for filters with harmonic frequencies of >1.3 kHz
- E62: single phase capacitors for filters with substantial unbalanced loads.

Consult our catalogue brochures for details of the a.m. capacitor ranges. Please refer also to our Application Notes for specific instructions and formulas related to high frequency filters.



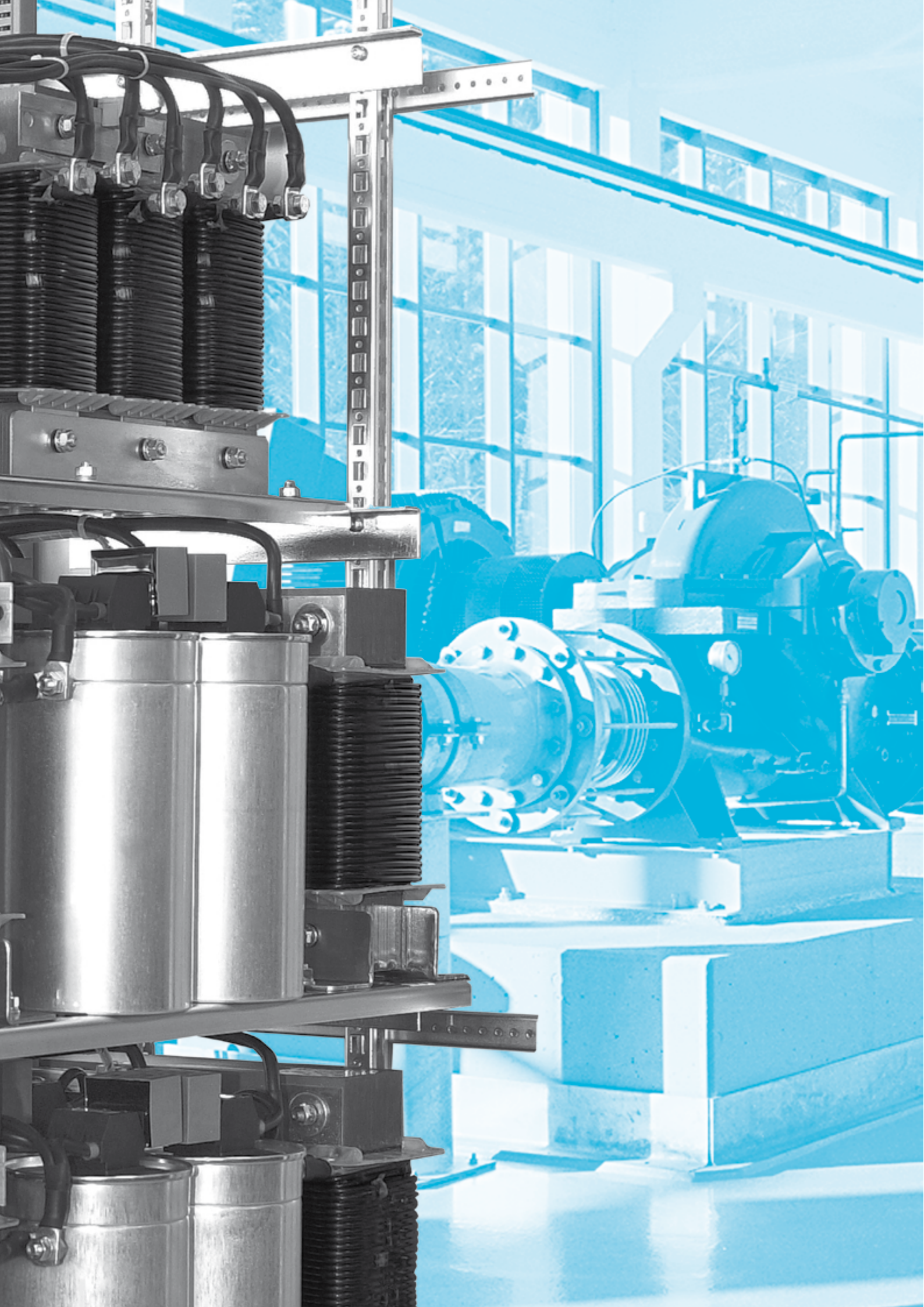

# FACTORY MATCHED TO WORK IN PERFECT HARMONY. ALL KEY COMPONENTS FROM ONE SOURCE.

The construction of reliable equipment for power factor correction requires not only your excellent experience, but also top-class components. No compromise in quality and safety should be permitted when it comes to the key parts of your PFC equipment. Because we do care, we are offering you the full set of essential components for your capacitor bank.



## THE HEART:

Capacitors. Without them, PFC is impossible. They are the most sensitive and most important component.  
Pages 14 to 35



## THE MUSCLE:

Switching is one of the key functions in your PFC, and switching capacitors means maximum stress.  
Pages 36 to 50



## THE PROTECTION:

Most PFC nowadays cannot do without detuning reactors for harmonic protection anymore.  
Pages 50 to 64



## THE BRAIN:

The controller shall know what to do, and when.  
Pages 66 to 70



## POWER CAPACITORS

Apart from your excellent experience, the construction of reliable and competitive equipment for power factor correction requires top-class components at reasonable cost. No compromise in quality and safety should be permitted when it comes to the key part of your PFC equipment. Germany's largest manufacturer of power capacitors manufactures all components with highest care and expertise and is your best choice for power capacitors.

The dry-type phase shifters of our renowned MKPg™-series are environmentally friendly, compact, and very convenient to handle. They contain no liquids, are filled with a neutral, inert gas entirely harmless to environment and may be mounted in any desired position. Should leakage occur, the leaking gas would escape into the atmosphere causing no undesirable effects to the adjacent equipment, e.g. damage, pollution, or staining. Hence when disposing of the capacitors, no liquids or toxic gasses need to be considered. The plant oil in our MKP capacitors is biodegradable and does not cause any trouble either, be it in the unlikely event of leakage or during disposal.

All our three-phase capacitors contain three separate capacitor elements connected in delta, preferably of short height and large diameter which substantially reduces inherent power losses and improves their current strength as compared with slim, tall capacitors. By using the market's best low-loss, self-healing polypropylene films and sophisticated manufacturing techniques such as high-vacuum drying and special coating patterns, they provide long service life with constant capacitance and high switching strength. As a matter of course, all our power capacitors are provided with BAM™ (overpressure break-action mechanism) as standard, for safe mode of failure.

Our original CAPAGRIP™ terminals guarantee optimum sealing of the capacitors, and offer convenient connection of cables up to 50mm<sup>2</sup>. A special spring system guarantees reliable and durable operation of the clamp. They are rated IP20, i.e. protected against accidental finger contact with live parts. Whilst the options K and L4 ("CAPAGRIP II") include bleeding resistors for a discharge below 50 V within up to 60 sec as standard, options L and M also permit the direct connection of discharge reactors and discharge resistor modules, as well as easy parallel connection of additional capacitors within the current limits of the terminal.



# POWER CAPACITORS





# INTERNAL CONSTRUCTION



## Dielectric

MKP-/MKPg-type capacitors are based on a low-loss dielectric formed by pure polypropylene film. A thin mixture of zinc and aluminium is metallized directly on one side of the PP-film under vacuum. Our long term experience as well as on-going research and improvements in this technology ensure the excellent self-healing characteristics of the dielectric and a long operating life of our capacitors. The plastic film is wound into stable cylindrical windings on the most modern automated equipment. The ends of the capacitor windings are contacted by spraying with a metal contact layer, facilitating a high current load and ensuring a low-inductance connection between the terminals and windings.

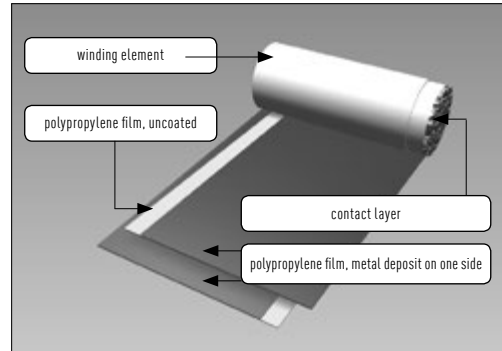

pic.2



The link between PP-film and zinc contact layer is highly stressed during high surge or rms currents and therefore considered very critical for operating life and reliability of the capacitor. By cutting the film for selected types in a wavelike manner, our SINECUT™ technology increases the contact surface between film and zinc layer which substantially reduces this strain.



## Impregnants

The use of impregnants and/or filling materials in capacitors is necessary in order to insulate the capacitor electrodes from oxygen, humidity, and other environmental interference. Without such insulation, the metal coating would corrode, an increasing number of partial discharges would occur, the capacitor would lose more and more of its capacitance, suffer increased dielectric losses and a reduced operating life. Therefore, an elaborate vacuum-drying procedure is initiated immediately after insertion of the capacitor elements into the aluminium case and dried insulation gas (MKPg), or biologically degradable plant oil (MKP), is introduced. Both protect the winding from environmental influence and provide an extended life-expectancy and stable capacitance.



## MKPg 265 – Leakage Proof and Environmentally Friendly

The gas in our MKPg-Capacitors is inert and entirely harmless to environment. When disposing of the capacitors, no liquids or toxic gasses need to be considered. Leakage of gas is extremely unlikely if the capacitors are handled and operated properly. It is possible to mount these capacitors in any desired position. However, should leakage occur, the leaking gas would escape into the atmosphere causing no undesirable effects to the adjacent equipment, e.g. damage, pollution, or staining. In the long run, such an unlikely event would result in a degradation of the capacitance; however, this process would take many months, during which the capacitor remains functional. By using gas, we are reducing the weight of a capacitor on average by 15% compared with resin or oil filled capacitors. This makes transportation and handling of the units easier. It also supports the concept of mounting the capacitors in almost any position.

# SAFE OPERATION



## Protection against Overvoltages and Short Circuits: Self-Healing Dielectric

All dielectric structures used in our power capacitors are "self-healing": In the event of a voltage breakdown the metal layers around the breakdown channel are evaporated by the temperature of the electric arc that forms between the electrodes. They are removed within a few microseconds and pushed apart by the pressure generated in the centre of the breakdown spot. An insulation area is formed which is reliably resistive and voltage proof for all operating requirements of the capacitor. The capacitor remains fully functional during and after the breakdown.



For voltages within the permitted testing and operating limits the capacitors are short-circuit- and overvoltage proof. They are also proof against external short circuits as far as the resulting surge discharges do not exceed the specified surge current limits.

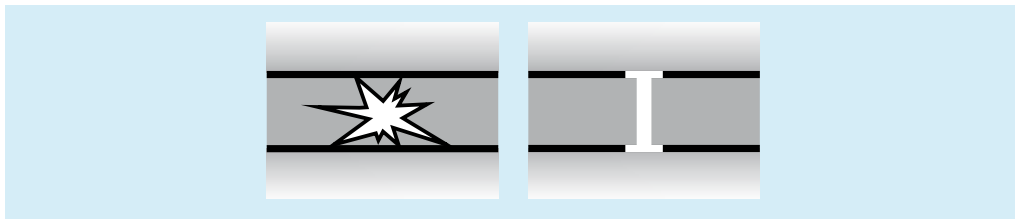

Self-healing breakdown

pic.3

## Protection Against Accidental Contact

All capacitors are checked by routine test (voltage test between shorted terminations and case:  $U_{60} \geq 2 U_N + 2000 \text{ V}$ , at least 3000V) in accordance with IEC 60831. Accessible capacitors must be earthed at the bottom stud or with an additional earthing clamp.

The CAPAGRIP™ terminal blocks are rated IP20, i.e. they are protected against accidental finger contact with live parts. The discharge modules are designed in the same way (compare page 45). Unused contact cages of design M terminal blocks must be covered by a proper blank (available as standard accessory, see page 49).



CAPAGRIP™

## SAFE OPERATION



### Protection against Overload and Failure at the end of Service Life

In the event of overvoltage, thermal overload or ageing at the end of the capacitor's useful service life, an increasing number of self-healing breakdowns may cause rising pressure inside the capacitor. To prevent it from bursting, the capacitor is fitted with an obligatory «**break action mechanism**» (**BAM™**). This safety mechanism is based on an attenuated spot at one, two, or all of the connecting wires inside the capacitor.

All capacitors with diameters < 85 mm as well as some traditional models with large diameters are provided with BAM 1 mechanism. All new models with diameters ≥ 85 mm will be provided with BAM 2 mechanism.

With rising pressure the case begins to expand, mainly by opening the folded crimp and pushing the lid upwards. As a result, the prepared connecting wires are separated at the attenuated spot, and the current path is interrupted irreversibly. It has to be noted that this safety system can act properly only within the permitted limits of loads and overloads.

BAM 1

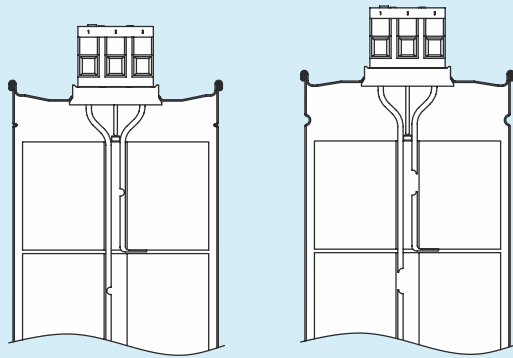

BAM 2

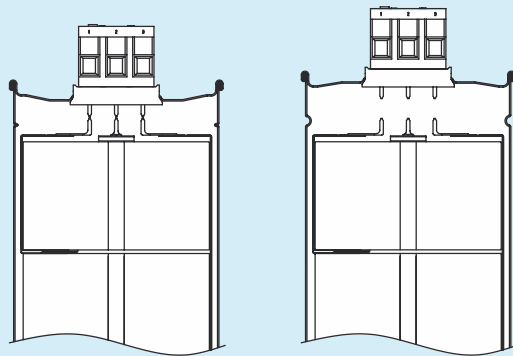

before activation



after activation

pic.4



### Mind hazards of explosion and fire

Capacitors consist mainly of polypropylene (up to 90 %), i.e. their energy content is relatively high. They may rupture and ignite as a result of internal faults or external overload (e.g. temperature, over-voltage, harmonic distortion). It must therefore be ensured, by appropriate measures, that they do not form any hazard to their environment in the event of failure or malfunction of the safety mechanism.



Fire Load: approx. 40 MJ/kg

Extinguish with: dry extinguisher (CO<sub>2</sub>, foam), or other fire extinguishants suitable for this voltage level

# DESIGN DRAWINGS

## CAPAGRIP™ K, L, M AND CAPAGRIP II™: EASE OF ASSEMBLY WITH HIGH DEGREE OF PROTECTION

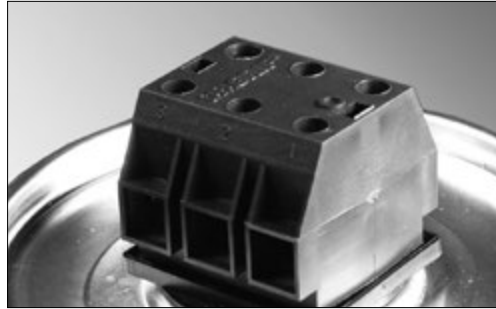
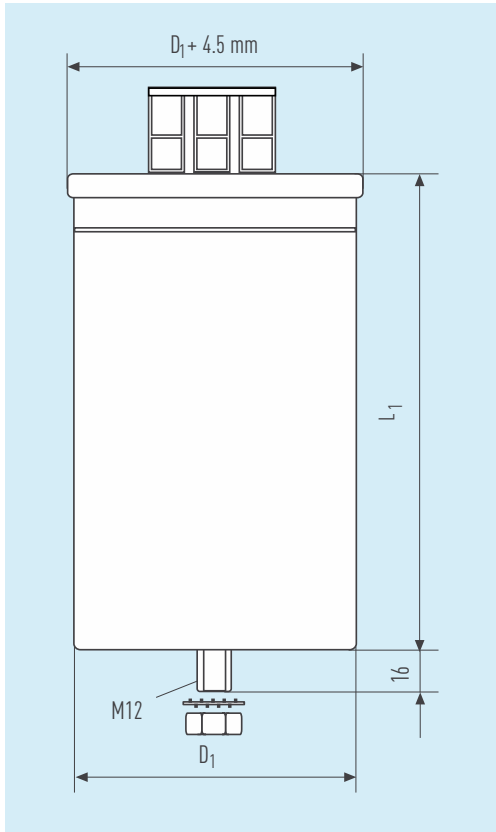

The CAPAGRIP™ terminals guarantee optimum sealing of the capacitors, and offer convenient connection of cables up to 50 mm<sup>2</sup>. A special spring system guarantees reliable and durable operation of the clamp.

Whilst CAPAGRIP™ K and CAPAGRIP II™ ("L4") incorporate bleeding resistors, designs L and M permit the direct connection of discharge reactors and discharge resistor modules, as well as easy parallel connection of additional capacitors within the limits of the current capability of the respective terminal.

For single phase versions, the central screw has no contact.

<b>Series</b>	<b>MKPg 265, MKP 266</b>
Protection	IP20
Humidity class	C
Creepage distance	16 mm
Air clearance	16 mm

If flat over the entire width of the cage, the body inserted into the terminal must have a thickness of at least 1.2 mm in order to get gripped and fixed by the clamp cage. See chart 5 for minimum thickness of inserted conductor if round-shaped and/or NOT ranging over the entire width of the cage.

See also chart 9 on page 34 for more detailed instructions on connectors and cable sizes.

CAPAGRIP™	Clamp width (mm)	minimum conductor height (if < 0.8 × clamp width)
K	5	2
L, L4	7	2.5
M	10	2.5

chart 5

## DESIGN DRAWINGS

CAPAGRIP™K

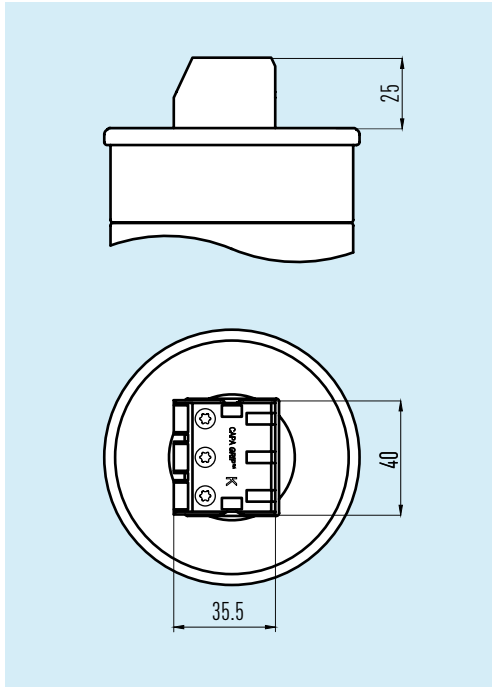

Available for diameters 60 ... 85 mm.

### Case

extruded aluminium can with base mounting stud M12, hermetically sealed by aluminium lid (folded edge)

### Terminal block

Steel clamp with T20 M4 screws in flame retardant plastic body (UL94:V0)

max. cable cross section:  $1 \times 10 \text{ mm}^2$  per phase  
max. terminal rating: 39 A/phase

Internal resistors for discharge < 50 V within < 60 s

CAPAGRIP™L4

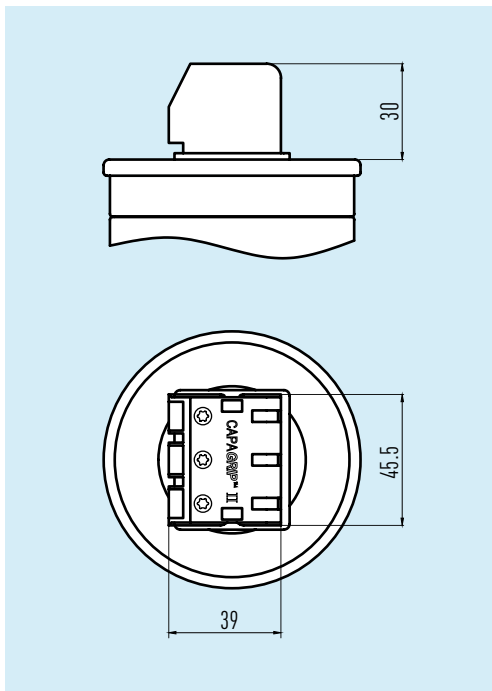

Available for diameters 85 ... 136 mm.

### Case

extruded aluminium can with base mounting stud M12, hermetically sealed by aluminium lid (folded edge)

### Terminal block

Steel clamp with T20 M5 screws in flame retardant plastic body (UL94:V0)

max. cable cross section:  $1 \times 25 \text{ mm}^2$  per phase  
max. terminal rating: 56 A/phase

Internal resistors for discharge < 50 V within < 60 s

## DESIGN DRAWINGS

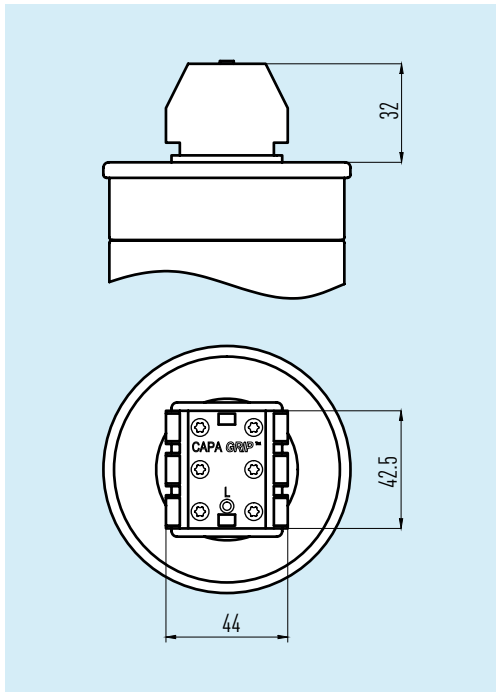

CAPAGRIP™ L

Available for diameters 85 ... 136 mm.

**Case**

extruded aluminium can with base mounting stud M12, hermetically sealed by aluminium lid (folded edge)

**Terminal block**

Steel clamp with T20 M5 screws in flame retardant plastic body (UL94:V0)  
 max. cable cross section: 2 × 25 mm<sup>2</sup> per phase  
 max. terminal rating: 56 A/phase

discharge resistors: available as separate item (see pgs. 45ff)

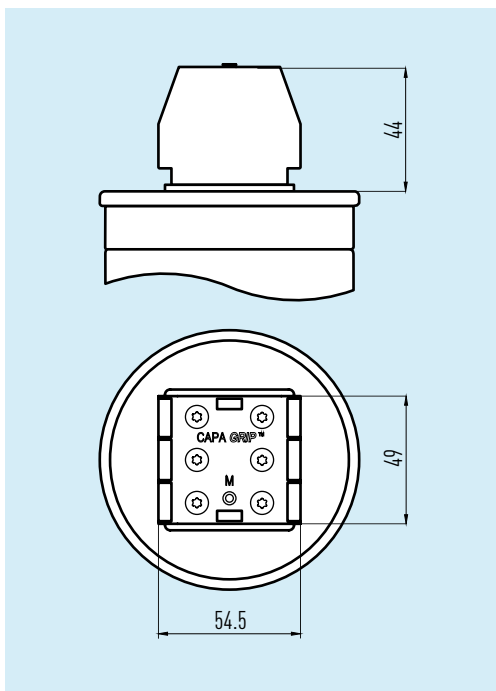

CAPAGRIP™ M

Available for diameters 95 ... 136 mm.

**Case**

extruded aluminium can with base mounting stud M12, hermetically sealed by aluminium lid (folded edge)

**Terminal block**

Steel clamp with T20 M6 screws in flame retardant plastic body (UL94:V0)  
 max. cable cross section: 2 × 50 mm<sup>2</sup> per phase  
 max. terminal rating: 104 A/phase

discharge resistors: available as separate item (see pgs. 45ff)

## DEFINITIONS AND SELECTION CRITERIA

**Rated Voltage  $U_N$** 

Root mean square of the max. permissible value of sinusoidal AC voltage in continuous operation. The rated voltage of the capacitors indicated in the data charts must not be exceeded even in cases of malfunction. Bear in mind that capacitors in detuned equipment are exposed to a higher voltage than that of the rated mains voltage; this is caused by the connection of detuning reactor and capacitor in series. Consequently, capacitors used with reactors must have a voltage rating higher than that of the regular mains voltage (compare  $U_c$  on page 55). Unless indicated otherwise, all voltages stated in this catalogue are rms values.

**Maximum RMS Voltage  $U_{max}$** 

Maximum rms voltage, which the capacitor can be exposed to permanently. This value also considers the maximum reactive power and the resulting power losses of the capacitor.

**Test Voltage Between Terminals  $U_{BB}$** 

Routine test of all capacitors conducted at room temperature, prior to delivery. A further test with 80 % of the test voltage stated in the data sheet may be carried out once at the user's location.

**Voltage test between terminals and case  $U_{BG}$** 

Routine test of all capacitors between short-circuited terminals and case, conducted at room temperature. May be repeated at the user's location.

**Rated power  $Q_c$** 

Reactive power resulting from the ratings of capacitance, frequency, and voltage:  $Q_c = 2\pi f \cdot C \cdot U_N^2$

**Maximum RMS Current Rating  $I_{max}$** 

Maximum rms value of permissible current in continuous operation. The maximum permitted rms current for each particular capacitor is related either to construction features or to the current limits of the terminals. In accordance with IEC 60831 all ELECTRONICON capacitors are rated at least  $1.3 \times I_N$  (with  $I_N$  being the nominal current of the capacitor at rated voltage and frequency), allowing for the current rise from permissible voltage and capacitance tolerances as well as harmonic distortion. As a rule, our values of maximum permitted continuous current are substantially higher. The exact value for each capacitor can be found in the individual data sheet. Higher rms values can be implemented by adjustments in construction and are available on request.



**Continuous currents that exceed the  $I_{max}$  values specified in the data charts will lead to a build-up of heat in the capacitor and may cause reduced lifetime or premature failure. Permanent excess current may even result in malfunction of the capacitor's safety mechanisms, i.e. bursting or fire (see page 18).**

Care must be taken not to exceed the maximum voltage and current ratings when installing capacitors in close-tuned or detuned equipment (see data sheets for maximum ratings). The thermal monitoring of reactors, or the use of overcurrent protection relays in the capacitor circuit is recommended to protect against overloads.



# DEFINITIONS AND SELECTION CRITERIA

## Current rating $I_N$

RMS value of the current at rated voltage and frequency, excluding harmonic distortion, switching transients, and capacitance tolerance.

It can be calculated by the formula  $I = \frac{Q_c}{U_N} = 2\pi f \cdot C \cdot U_N$  and is not stated in the data charts.



## Pulse current strength $I_s$

Depending on construction and voltage rating, the design of our capacitors permits short term inrush currents of  $100...400 \times I_N$  and – in accordance with IEC 60831 – up to 5000 switching operations per annum as standard. However, when switching capacitors in automatic capacitor banks without detuning reactors, higher loads are very often the case. This may generate negative effects on the operational life, especially with capacitors which are frequently connected and disconnected (e.g. primary stages in automatic capacitor banks). Moreover, even detuned capacitors may experience switching currents exceeding the permissible maximum current of the reactor and causing consequential damage to both capacitor and reactor.



**We strongly recommend the use of special capacitor contactors with inrush limiting resistors, or other adequate devices for limitation of the peak inrush currents.**



## Temperature category

The average useful life of a capacitor depends very much on the ambient temperatures it is operated at. The permissible operating temperatures are defined by the temperature class stated on the label which contains the lower limit temperature (-50°C) and a letter, which describes the values of the upper limit temperatures. Chart 6 is based on IEC 60831 and details the maximum permitted ambient temperatures for capacitors in each temperature category.



temperature category	ambient temperature limits		
	maximum	max. average 24 hrs	max. average 365 days
B	45°C	35°C	25°C
C	50°C	40°C	30°C
D	55°C	45°C	35°C
60	60°C	50°C	40°C
65	65°C	55°C	45°C

chart 6

## Lifetime Statements

Even though all our lifetime statements are based on many years of empirical data, testing and field statistics, they will always remain just a general prognosis based on data of the past and accelerated laboratory tests which cannot reflect all aspects of modern operating conditions. The real "lifetime" of our capacitors depends on a multitude of influencing factors, such as ambient temperatures, operating voltages, frequency of overvoltages, frequency of switching, system faults a.o. The lifetime estimations given in our data sheets are therefore linked with specific operating conditions (voltage and temperature).



It has also to be noted that any lifetime statement considers a certain percentage of permitted failures within a given lot, reflecting the fact that any component has a FIT rate (failures in time). Under rated operating conditions, our capacitors can be expected to have a FIT rate of no more than 300 (corresponding to a maximum failure rate of 3 %) during their initial 100,000 hours of operation..

**Please consult our sales teams if in doubt about the specific implications of your intended operating conditions on lifetime and reliability of our capacitors.**





## DATA CHARTS

rated voltages		230 ... 800 V, 60 Hz
permitted overvoltages and test voltages		in accordance with IEC EN 60831-1/2 (see data charts for details)
tolerance of capacitance		- 5 ... + 10 %, ± 5 % on request
maximum permissible current		at least 1.3 I <sub>N</sub> , see data charts for details
max. inrush current		300 x I <sub>N</sub>
dissipation losses (capacitor)		approx. 0.25 ... 0.40 W/kvar
internal connection		delta
safety device		BAM™ (overpressure break action mechanism)
dielectric material		low-loss polypropylene, dry
impregnant (filling material)	MKPg 265	inert insulation gas (N <sub>2</sub> )
	MKP 266	resin, based on vegetable oil
mounting position	MKPg 265	any position
	MKP 266	vertical position recommended
max. relative humidity		95 % (climatic class C)
operating temperatures		see data charts for ambient temperature class
storage temperature		-50 ... +85°C
max. altitude abv.s.l.		4000 m a.s.l.
statistical life expectancy		100,000 ... 150,000 h depending on type range and operating temperatures (see charts for details)
applied standards		IEC EN 60831, VDE 0560-46/47 UL Standard No. 810, CSA C22.2 No. 190, GOST 1282-88, IS 13340/13341
approval marks	 	<b>all capacitors in this catalogue:</b> UL/C-UL recognized component, 10,000AFC internally protected <b>selected items:</b> CSA (C/US)

General  
Technical  
Data

DATA CHARTS

All capacitors listed in this catalogue comply with the relevant regulations and guidelines of the European Union: 2014/35/EU (Low-Voltage Directive).

This is proven by the technical documentation and compliance with the following standard: IEC/DIN EN 60831-1/2:2014





## MKPg™ 265.\*\*\* 3PH GAS-FILLED 230 ... 280 V 60Hz

for latest edition and updates  
check [www.powercapacitors.info](http://www.powercapacitors.info)



Three-phase power capacitors, dry self-healing dielectric, gas-filled (N<sub>2</sub>)  
For detuned and non-detuned PFC equipment in mains with severe operating conditions or substantial voltage fluctuations.

U <sub>N</sub>	Θ <sub>ambient</sub>	statistical life
230V	-50/60	>150,000 h
260V	-50/D	>150,000 h
280V	-50/D	>130,000 h

Permitted overvoltages	
8h/d	308V
30min/d	320V
5min (200×)	335V
1min (200×)	365V
max. peak voltage	850V ac

CAPA**GRIP**™ K and II (L4) including discharge resistors. For L and M see resistor modules on pages 46f.

Q <sub>c</sub> 280V (kvar)	Q <sub>c</sub> 260V (kvar)	Q <sub>c</sub> 230V (kvar)	C <sub>N</sub> (μF)	I <sub>max</sub> (A)	D <sub>1</sub> × L <sub>1</sub> (mm)	m (kg)	CAPA <b>GRIP</b>	order no.	packg.lot / box
3.5	3.1	2.5	3 × 40	3 × 13	60 × 164	0.4	K	265.525-304000	10/FB8
5.6	5.0	3.8	3 × 63	3 × 30	75 × 164	0.7	K	265.545-306300	5/FB8
7.5	6.3	5.0	3 × 84	3 × 31	85 × 164	1	L4	265.255-308400	5/FB8
11.0	9.6	7.5	3 × 125	3 × 35	75 × 230	1	K	265.546-312500	5/FB9
11.6	10.0	7.8	3 × 131	3 × 36	75 × 230	1	K	265.546-313100	5/FB9
15.0	12.5	10.0	3 × 167	3 × 47	85 × 230	1.3	L4	265.256-316700	5/FB9
17.4	15.0	11.7	3 × 196	3 × 54	95 × 230	1.5	L4	265.266-319600	3/FB9
18.5	16.0	12.5	3 × 209	3 × 56	95 × 230	1.5	L4	265.266-320900	3/FB9
22.2	19.2	15.0	3 × 251	3 × 56	100 × 230	1.7	L4	265.276-325100	3/FB9
22.2	19.2	15.0	3 × 251	3 × 69	100 × 230	1.7	M	265.376-325100	3/FB9
23.2	20.0	15.7	3 × 262	3 × 70	100 × 245	1.8	M	265.378-326200	3/FB12
30.0	25.0	20.0	3 × 333	3 × 80	116 × 230	2.3	M	265.386-333300	3/FB9

Other sizes and ratings are available on request. Single phase capacitors are available on request in same dimensions and design.  
Mind Mounting and Operating Instructions on pages 32ff!

# MKPg™

## 265.\*\*\* 3PH GAS-FILLED

### 380 ... 480 V 60Hz



Three-phase power capacitors, dry self-healing dielectric, gas-filled (N<sub>2</sub>)  
For detuned and non-detuned PFC equipment in mains with standard operating conditions

U <sub>N</sub>	Θ <sub>ambient</sub>	statistical life
380...400V	-50/60 (*-50/D)	>150,000 h
440V	-50/D	>150,000 h
480V	-50/C	>100,000 h

#### Permitted overvoltages

8h/d	530V	1min (200×)	625V
30min/d	555V	max. peak voltage	1425V ac
5min (200×)	580V		

CAPA **GRIP**™ K and II (L4) including discharge resistors. For L and M see resistor modules on pages 46f.

Q <sub>c</sub> 480V (kvar)	Q <sub>c</sub> 440V (kvar)	Q <sub>c</sub> 400V (kvar)	Q <sub>c</sub> 380V (kvar)	C <sub>N</sub> (μF)	I <sub>max</sub> (A)	D <sub>1</sub> × L <sub>1</sub> (mm)	m (kg)	CAPA <b>GRIP</b>	order no.	packg.lot / box
5.5	4.6	3.8	3.4	3 × 21	3 × 11	60 × 164	0.4	K	265.525-502100	10/FB8
7.3	6.1	5	4.6	3 × 28	3 × 15	60 × 196	0.7	K	265.523-502800	10/FB9
10.4	8.8	7.3	6.5	3 × 40	3 × 25	75 × 164	0.7	K	265.545-504000	10/FB8
12	10	8.3	7.5	3 × 46	3 × 25	85 × 164	1	L4	265.255-504600	5/FB8
14.3	12	10	9	3 × 55	3 × 26	75 × 230	1	K	265.546-505500	5/FB9
15	12.5	10.5	9.4	3 × 58	3 × 27	75 × 230	1	K	265.546-505800	5/FB9
17.7	15	12.3	11.1	3 × 68	3 × 32	75 × 245	1	K	265.548-506800	10/FB12
20	16.9	13.9	12.5	3 × 77	3 × 36	85 × 230	1.3	L4	265.256-507700	5/FB9
21.6	18.2	15	13.5	3 × 83	3 × 40	85 × 230	1.5	L4	265.256-508300	5/FB12
24	20	16.6	15	3 × 92	3 × 43	85 × 245	1.5	L4	265.258-509200	5/FB12
28.9	24	20	18	3 × 111	3 × 52	95 × 230	1.5	L4	265.266-511100	3/FB9
-	30	25	22.4	3 × 137	3 × 56	100 × 245	1.8	L4	265.278-513700	3/FB12
-	33.7	27.9	25	3 × 154	3 × 56	116 × 230	2.3	L4	265.286-515400	3/FB9
-	36	30	27	3 × 166	3 × 56	116 × 230	2.3	L4	265.286-516600	3/FB9
-	40	33.3	30	3 × 185	3 × 68	116 × 280	2.6	M	265.389-518500	3/FB10
-	-	40*	36	3 × 221	3 × 75	116 × 280	2.6	M	265.389-522100	3/FB10

Other sizes and ratings are available on request. Single phase capacitors are available on request in same dimensions and design.  
Mind Mounting and Operating Instructions on pages 32ff!

## MKPg™ 265.\*\*\* 3PH GAS-FILLED 400 ... 525 V 60Hz



Three-phase power capacitors, dry self-healing dielectric, gas-filled (N<sub>2</sub>)

For detuned and non-detuned PFC equipment in 400 or 440V mains with severe operating conditions or substantial voltage fluctuations, or 480V mains with standard operating conditions.

U <sub>N</sub>	Θ <sub>ambient</sub>	statistical life
400 V	-50/65	>150,000 h
440 V	-50/60 (*-50/D)	>150,000 h
480 V	-50/D	>150,000 h
525 V	-50/D	>100,000 h

### Permitted overvoltages

8h/d	580V	1min (200×)	680V
30min/d	600V	max. peak voltage	1600V ac
5min (200×)	630V		

For resistor modules see pages 46f.

Q <sub>C</sub> 525V (kvar)	Q <sub>C</sub> 480V (kvar)	Q <sub>C</sub> 440V (kvar)	Q <sub>C</sub> 400V (kvar)	C <sub>N</sub> (μF)	I <sub>max</sub> (A)	D <sub>1</sub> × L <sub>1</sub> (mm)	m (kg)	CAPA GRIP	order no.	packg.lot / box
5.9	5	4.17	3.4	3 × 19	3 × 11	65 × 164	0.5	K	265.535-601900	10/FB8
9	7.5	6.3	5.2	3 × 29	3 × 15	75 × 164	0.7	K	265.545-602900	10/FB9
11.8	10	8.3	6.9	3 × 38	3 × 20	65 × 245	0.9	K	265.538-603800	10/FB9
15	12.5	10.5	8.7	3 × 48	3 × 25	75 × 230	1	K	265.546-604800	5/FB9
18	15	12.5	10.5	3 × 58	3 × 26	75 × 280	1.3	K	265.549-605800	5/FB10
25	20	17.3	14.3	3 × 79	3 × 41	85 × 245	1.5	L4	265.258-607900	5/FB12
30	25	21	17.3	3 × 96	3 × 50	95 × 245	1.8	L4	265.268-609600	3/FB12
36	30	25	20.8	3 × 115	3 × 56	116 × 230	2.3	L	265.186-611500	3/FB9
36	30	25	20.8	3 × 115	3 × 56	95 × 280	2.2	L4	265.269-611500	3/FB10
48	40	33.7	27.9	3 × 154	3 × 80	136 × 230	3.7	M	265.396-715401	2/FB12
-	50	42*	34.7	3 × 192	3 × 80	136 × 295	4.1	M	265.398-719200	2/FB11

Other sizes and ratings are available on request. Single phase capacitors are available on request in same dimensions and design. Mind Mounting and Operating Instructions on pages 32ff!

# MKPg™

## 265.\*\*\* 3PH GAS-FILLED

### 440 ... 525 V 60Hz



Three-phase power capacitors, dry self-healing dielectric, gas-filled (N<sub>2</sub>)  
 For detuned and non-detuned PFC equipment in mains with severe operating conditions or substantial voltage fluctuations.

U <sub>N</sub>	Θ <sub>ambient</sub>	statistical life
440V	-50/65	>150,000 h
480V	-50/60	>150,000 h
525V	-50/D	>150,000 h

Permitted overvoltages	
8h/d	580V
30min/d	600V
5min (200×)	630V
1min (200×)	680V
max. peak voltage ..... 1600V ac	

CAPAGRIP™ K and II (L4) including discharge resistors. For L and M see resistor modules on pages 46f.

Q <sub>N</sub> 525V (kvar)	Q <sub>N</sub> 480V (kvar)	Q <sub>C</sub> 440V (kvar)	C <sub>N</sub> (μF)	I <sub>max</sub> (A)	D <sub>1</sub> × L <sub>1</sub> (mm)	m (kg)	CAPA GRIP	order no.	packg.lot / box
3.1	2.5	2.2	3 × 10	3 × 6	60 × 164	0.4	K	265.525-801000	10/FB8
4.4	3.7	3	3 × 14	3 × 9	60 × 164	0.5	K	265.525-701400	10/FB8
6	5	4.17	3 × 19	3 × 10	60 × 230	0.7	K	265.526-701900	10/FB9
6.5	5.5	4.6	3 × 21	3 × 13	75 × 164	0.7	K	265.545-702100	5/FB8
7.5	6.3	5	3 × 24	3 × 14	75 × 164	1	K	265.545-702400	5/FB8
9	7.5	6.3	3 × 29	3 × 15	65 × 230	0.7	K	265.536-702900	10/FB9
12	10	8.3	3 × 38	3 × 20	75 × 230	1	K	265.546-703800	5/FB9
13.9	11.6	10	3 × 44.5	3 × 23	85 × 230	1.3	L4	265.256-704500	5/FB9
15	12.5	10	3 × 48	3 × 25	85 × 230	1.3	L4	265.256-704800	5/FB9
18	15	12.5	3 × 58	3 × 30	95 × 230	1.5	K	265.566-705800	3/FB9
20	16.7	14	3 × 64	3 × 33	95 × 230	1.5	L4	265.266-706400	3/FB9
24	20	16.9	3 × 77	3 × 40	100 × 245	1.8	L4	265.278-707700	3/FB12
27.7	23	20	3 × 89	3 × 46	116 × 230	2.3	L4	265.286-708900	3/FB9
30	25	21	3 × 96	3 × 50	116 × 230	2.3	L4	265.286-709600	3/FB9
35.9	30	25	3 × 115	3 × 56	116 × 280	2.6	L4	265.289-711500	3/FB10
40	33.3	28	3 × 128	3 × 65	136 × 230	2.9	M	265.396-712800	2/FB9

Other sizes and ratings are available on request. Single phase capacitors are available on request in same dimensions and design.  
 Mind Mounting and Operating Instructions on pages 32ff!



# MKPg™

## 265.\*\*\* 3PH GAS-FILLED 480 ... 800 V 60Hz



for latest edition and updates  
check [www.powercapacitors.info](http://www.powercapacitors.info)



Three-phase power capacitors, dry self-healing dielectric, gas-filled (N<sub>2</sub>)  
For detuned and non-detuned PFC equipment in 690V mains with normal operating conditions or substantial voltage fluctuations.

U <sub>N</sub>	Θ <sub>ambient</sub>	statistical life
480V	-50/65	>150,000 h
600V	-50/60	>150,000 h
690V	-50/D	>130,000 h
760V	-50/D	>100,000 h

Permitted overvoltages		
8h/d	840V	1min (200×) ..... 990V
30min/d	875V	max. peak voltage .... 2300V ac
5min (200×)	915V	

For resistor modules see pages 46f.

Q <sub>C</sub> 760V (kvar)	Q <sub>C</sub> 690V (kvar)	Q <sub>C</sub> 600V (kvar)	Q <sub>C</sub> 480V (kvar)	C <sub>N</sub> (μF)	I <sub>max</sub> (A)	D <sub>1</sub> × L <sub>1</sub> (mm)	m (kg)	CAPA GRIP	order no.	packg.lot / box
5	4.17	3.1	2	3 × 7.7	3 × 8	75 × 164	0.7	K	265.545-597700	5/FB8
6.3	5	4	2.5	3 × 9.7	3 × 9	75 × 164	0.7	K	265.545-401000	5/FB8
12.5	10	7.5	5	3 × 19	3 × 15	75 × 230	1	K	265.546-401900	5/FB9
30	25	18.7	12	3 × 46	3 × 35	116 × 230	2.3	L	265.186-404600	3/FB9
-	30	22.8	15	3 × 56	3 × 39	116 × 230	2.6	L	265.186-405600	3/FB10
40	33.3	25	16	3 × 62	3 × 47	116 × 280	2.6	L	265.189-406200	3/FB10
-	-	30	19.3	3 × 74	3 × 54	116 × 280	2.6	L	265.189-407400	3/FB10
-	50	37.4	24	3 × 93	3 × 55	136 × 280	3.7	M	265.399-409300	2/FB10

U <sub>N</sub>	Θ <sub>ambient</sub>	statistical life
480V	-50/65	>150,000 h
600V	-50/60	>150,000 h
690V	-50/D	>130,000 h
800V	-50/D	>100,000 h

Permitted overvoltages		
8h/d	880V	1min (200×) ..... 1040V
30min/d	920V	max. peak voltage .... 2400V ac
5min (200×)	960V	

For resistor modules see pages 46f.

Q <sub>C</sub> 800V (kvar)	Q <sub>C</sub> 690V (kvar)	Q <sub>C</sub> 600V (kvar)	Q <sub>C</sub> 480V (kvar)	C <sub>N</sub> (μF)	I <sub>max</sub> (A)	D <sub>1</sub> × L <sub>1</sub> (mm)	m (kg)	CAPA GRIP	order no.	packg.lot / box
20	15	11.4	7.5	3 × 28	3 × 21	95 × 230	1.5	L	265.166-502800	3/FB9
27	20	15	10	3 × 37	3 × 38	116 × 230	2.3	L	265.186-503700	3/FB9
35.5	26.4	20	12.5	3 × 49	3 × 49	116 × 280	2.6	L	265.189-504900	3/FB10
40	29	22	14.2	3 × 54.4	3 × 55	116 × 280	2.6	L	265.189-505401	3/FB10

Other sizes and ratings are available on request. Single phase capacitors are available on request in same dimensions and design.  
Mind Mounting and Operating Instructions on pages 32ff!

# MKP

## 266.\*\*\* 3PH OIL-FILLED

### 480 ... 800V 60Hz



Three-phase power capacitors, dry self-healing dielectric, gas-filled (N<sub>2</sub>)  
 For detuned and non-detuned PFC equipment in 690V mains with normal operating conditions or substantial voltage fluctuations.

U <sub>N</sub>	Θ <sub>ambient</sub>	statistical life
480 V	-50/65	>150,000 h
600 V	-50/60	>150,000 h
690 V	-50/D	>130,000 h
800 V	-50/D	>100,000 h

Permitted overvoltages		
8h/d	880V	1min (200×) .....1040V
30min/d	920V	max. peak voltage .....2400V ac
5min (200×)	960V	

For resistor modules see pages 46f

Q <sub>c</sub> 800V (kvar)	Q <sub>c</sub> 690V (kvar)	Q <sub>c</sub> 600V (kvar)	Q <sub>c</sub> 480V (kvar)	C <sub>N</sub> (μF)	I <sub>max</sub> (A)	D <sub>1</sub> × L <sub>1</sub> (mm)	weight (kg)	CAPA <b>GRIP</b>	part no.	packg.lot / box
20	13.5	10	6.5	3 × 25	3 × 25	95 × 230	2	L	266.166-502500	3/FB9
35	26.4	20	12.5	3 × 49	3 × 50	116 × 280	2.9	L	266.189-504900	3/FB10
40.5	30	23	15	3 × 56	3 × 56	136 × 230	3.2	M	266.396-505601	2/FB9

Other sizes and ratings are available on request. Single phase capacitors are available on request in same dimensions and design.  
 Mind Mounting and Operating Instructions on pages 32ff!

# MOUNTING INSTRUCTIONS



Safe operation of the capacitors can be expected only if all electrical and thermal specifications as stated on the label, in the data sheets or catalogues and the following instructions are strictly observed. ELECTRONICON does not accept responsibility for whatever damage may arise out of a non-observance.



## Mounting Position

Oil-filled MKP 266 capacitors shall be installed upright with terminals facing upwards. Gas-filled MKPg 265 capacitors can be mounted in any position without restrictions, however, a position with terminals pointing downwards should be avoided.



## Location/Cooling

The useful life of a capacitor may be reduced dramatically if exposed to excessive heat. Typically, an increase in the ambient temperature by 7°C will halve the expected life of the capacitor. The permitted temperature category of the capacitor is stated on the label. If extenuating circumstances give cause for doubt, special tests should be conducted by the user to ensure that the permitted maximum ambient temperature of the capacitor is not exceeded. It should be noted that the internal heat balance of large capacitors is only reached after a couple of hours.



To avoid overheating the capacitors must be allowed to cool unhindered and should be shielded from external heat sources. Do not place the capacitors directly above or next to heat sources such as detuning or tuning reactors, bus bars, etc. and make sure the connecting cables do not import additional heat via the terminals. We recommend forced ventilation for all applications with detuning reactors. Give at least 15 ... 20 mm clearance between the capacitors for natural convection or forced ventilation.



## Mounting

All cylindrical capacitors are fitted with a "break-action" safety mechanism (BAM™, see page 18) which may cause the case to expand, especially at the crimp and at the lid.

- The folded edge of the lid must not be retained by clamps.
- A clearance of at least 35mm above the terminations shall be accommodated.
- Required clearances according to applicable voltage category must be maintained even after activation of the BAM™ and prolongation of the can.

The hermetic sealing of the capacitors is crucial for a long operating life and for the correct functioning of the beak action mechanism. Please pay special attention not to damage the following critical sealing points:

- the folded edge of the lid
- the connection between screw terminal and lid (designs K, L, L4, M)



The folded edge and the connection terminals must not be hit with heavy or sharp objects or tools (e.g. hammer, screw driver).



## Fixation

All cylindrical capacitors can be fixed sufficiently using the mounting stud at the base of the can. Make sure to insert the washer which is delivered along with the mounting nut.

mounting stud	Permitted max. torque
M8	5 Nm
M12	15 Nm

chart 7

# MOUNTING INSTRUCTIONS

## Vibration stress according to DIN IEC 60068-2-6

Please consult us for details of permitted vibration stress in your application.

Note that capacitors fitted with the EL-Dr discharge reactor must not be exposed to any vibration stress at all.

## Connection

Fuses and cross section of the leads should be sized for at least 1.5 times of the rated capacitor current ( $I_N$ ). Please ensure that the permitted maximum rms current according to data chart ( $I_{max}$ ) is not exceeded. Do not exceed the permitted nominal current values per contact as specified in chart 8 even when coupling capacitors in parallel.



The capacitors shall only be connected with flexible cables or elastic copper bands to ensure unrestricted functioning of the expansion mechanism (BAM™).

Stranded cables should be fitted with ferrules when connected to the CAPAGRIP terminals. See chart 8 for minimum cable size if used **without** ferrules. Make sure to use cables with fine or medium strands only.

**The solder joints on the capacitor lids guarantee the hermetical sealing of the capacitors and must not be exposed to excessive heat.**



**The CAPAGRIP™ terminals (design K, L, L4, M) must not be bent, twisted or moved in any other way.**

## Selection of cables

Cables used for the connection of power capacitors must not contribute to the power losses of the capacitor. It may therefore be appropriate to select cable sizes in excess of the minimum permitted cross sections usually specified by cable manufacturers.



Chart 8 is based on DIN VDE 0100-430 and IEC 60439-1 and related to the operation of three or four bundled copper cables at an average ambient temperature of 40°C. Mind that national rules or the standards of your application may require different ratings.

Chart 8 outlines the minimum requirements towards the connection of capacitors. We recommend dimensioning the cables for at least  $1.5 \times I_N$  where possible, and using one grade larger cable ratings if expecting higher ambient temperatures and/or substantial content of harmonics.

max. nominal capacitor current (A/phase)	e.g. $Q_{C,max}$ 480V 60Hz (kvar)	recommended cable section (mm <sup>2</sup> /phase)	max. recommended HRC fuse* (A)
6	5	1.5	25
12.3	10	2.5	32
16.2	13	4	35
20.8	17	6	40
28.5	24	10	63
37.7	30	16	80
50	40	25	125
60.8	50	35	125
76.2	63	50 / 35**	160

\* The recommended HRC fuses are rated for cable protection only.

\*\* Cables shall not be bundled.

chart 8

## MOUNTING INSTRUCTIONS

**Termination Torques**

Do not exceed the permitted torque of the terminal screws (design K, L/L4, M) and the mounting studs. The test values specified by IEC 61068 must be guaranteed as a minimum value.

All CAPAGRIP™ terminals are equipped with Torx screws (T20). Use of improper screw-drivers may damage the screws and impair reliable fixation.



Terminal design	Minimum size of inserted flat conductor W x H (mm)	Cable size with ferrule or plug (mm <sup>2</sup> )	Cable size if without ferrule (mm <sup>2</sup> )	Max. nominal current (A)	Recommended torque (Nm)
K	4 ... 4.8 x 1.2	2.5 ... 10	10	30	1.8 ... 2.5
L, L4	5.5 ... 6.8 x 1.2	10 ... 25	16 ... 25	43	2.5 ... 3.0
M	8 ... 9.8 x 1.2	16 ... 35	35 ... 50	80	4.0 ... 5.0

chart 9

**Discharge**

Standard IEC 60831 requires a safety discharge to  $\leq 75$  V within 3 minutes in order to protect maintenance personnel from accidental injury by residual voltage.

**Capacitors must be discharged and short-circuited before working on the terminals.**

In order to minimize the switching strain and to avoid high energizing currents by connection in phase opposition, capacitors shall be discharged to  $\leq 10$  % of the rated voltage prior to being re-connected if switched by mechanical devices (magnetic contactors). Note that in automatic capacitor banks, very often shorter discharge cycles may be required (e.g.  $< 50$  V within 60 seconds).



Use rapid discharge reactors or switchable discharge resistors for very short discharge cycles (see chapter "Switching and Discharging Capacitors", pgs. 36ff).

**Discharge Modules**

For capacitors in CAPAGRIP L/M, separate discharge modules in finger-proof housing (IP20) are available for the discharge of single units or groups of paralleled capacitors. The correct size of the module to be applied can be taken from the selection matrix on pg. 46f.

**The discharge resistors may become very hot (up to 200°C) during continuous operation!**

**For CAPAGRIP L/M only: Remove the lid of the discharge module if applying protective caps to the capacitors!**

Capacitors in CAPAGRIP K and CAPAGRIP II (L4) are equipped with internal discharge resistors for a discharge within no more than 60 seconds from their highest rated voltage to less than 50 V.

**Earthing**

Capacitors with a metal case must be earthed at the mounting stud or by means of a separate metal strap or clamp.

# MOUNTING INSTRUCTIONS

## Environment

All capacitors are made with lead-free solder tin and comply with the ROHS and REACH regulations. Our capacitors do not contain PCB, solvents, or any other toxic or banned materials. The impregnants and filling materials of MKP contain vegetable oil or polyurethane mixtures. The gas-filled MKPg™ capacitors contain only neutral, ecologically sound insulation gasses. Further details on the filling materials can be provided on request.



The capacitors do not contain hazardous substances acc. to European Directives 2003/53/EC and Council Directive 76/769/EEC. They are not classified as “**dangerous goods**” according to transit rules. The capacitors do not have to be marked under the regulations for Hazardous Goods. They are rated WGK 0 (water risk **category 0 “no general threat to water”**).



No danger for health if applied properly. In case of skin contact with filling liquids, clean with water and soap.

## Disposal

Capacitors are components of electrical devices. They are NOT equipment or devices by themselves, and not subject to the Waste Electrical and Electronic Equipment Directive (WEEE). We recommend disposing of the capacitors through professional recycling centers for electric/electronic waste.



The capacitors can be disposed of as follows:

- Disposal acc. to European waste catalogue (EWC) No. 16 02 16 (“Components removed from discarded equipment other than those mentioned in 16 02 15”).
- Liquid filling materials which may have emerged from the capacitor shall be absorbed by proper granules and disposed of in accordance with EWC No. 08 04 10 (“waste adhesives and sealants other than those mentioned in 08 04 09”).

**Caution: When touching or disposing capacitors with activated break-action mechanism, please consider that even after days and weeks these capacitors may still be charged with high voltages!**



Make also sure to consult your national rules and restrictions for waste and disposal.

## SWITCHING AND DISCHARGING

Our power capacitors are designed to withstand high surge currents manifold their rated current. Even so, repetitive high inrush currents may damage capacitors and should therefore be avoided by

- A. suppressing switching currents by the use of special capacitor contactors, see pages 38 to 40.



- B. eliminating inrush currents by the use of suitable thyristor switches, see pages 41 to 44.



- C. avoiding re-connection in phase opposition by the use of proper discharge resistors or reactors, see pages 45 to 49.

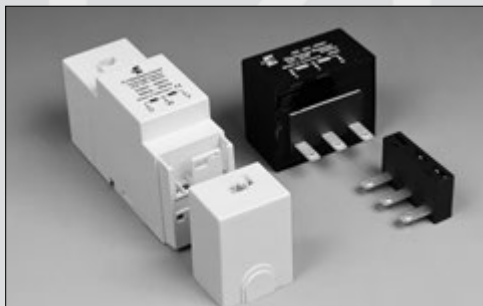



# SWITCHING AND DISCHARGING CAPACITORS

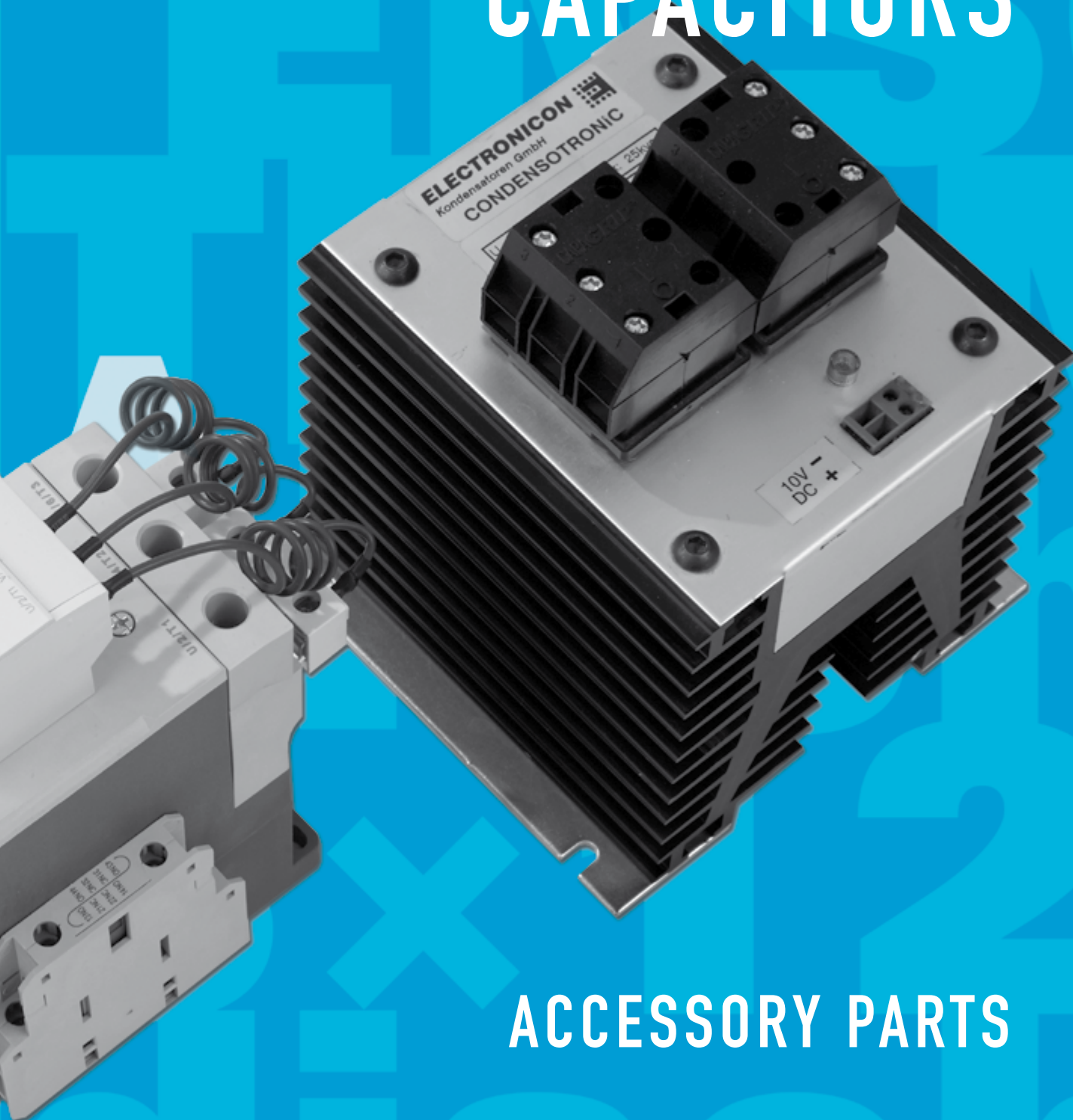

ACCESSORY PARTS

## CAPACITOR CONTACTORS 1301A SERIES



Power capacitors may enter high-frequency resonances with nearby inductances when being connected to the mains. Though vanishing within a few microseconds, such resonances lead to very high current surges which, if occurring regularly, may damage the capacitor elements. In accordance with IEC EN 60831-1/2, the annual number of switching operations for our standard capacitors is therefore recommended not to exceed 5000...6000 counts p.a. Special capacitors suitable for a higher annual number of switchings are available on request.

For flawless operation of our capacitors, we strongly recommend using special capacitor contactors with inrush-limiting ("leading") contacts. Such devices connect a pre-load channel several milliseconds prior to closing their main contact. This channel is choked down by special current limiting resistors and substantially softens the initial switching inrush surge, protecting the capacitors from destructive current surges and the contactors from premature deterioration or welding.

Our 1301A contactors are using a mechanical principle for switching the pre-load contacts. The pre-load contacts and damping resistors are supplied as a separate part and are snapped onto the main switch.

As soon as the main switch has been closed, the pre-load contacts are released again and their resistor wires taken out of circuit after no more than 5...10ms of operation. This avoids additional heat losses in the resistor wires during the operation of the capacitor branch, and contributes to the high reliability and long operational life of our contactors.

Since the disconnection of inductive loads is usually accompanied by switch arcs, the pre-load contacts of certain capacitor contactors may often face trouble when used with reactor-capacitor combinations (detuned capacitors) as they are lagging behind the main contact during the switch-off process. The contactors of our 1301A series are not affected by this problem as their pre-load contacts are already out of circuit. Hence they can be used for both detuned and non-detuned capacitor installations. ELECTRONICON strongly recommends the usage of contactors with pre-load contacts even for detuned capacitors in order to assure undisturbed switching and prevent ferro-resonances of the reactor during the start-up period.

The 1301A is enclosed in a compact, finger proof housing (IP20). Its sealed structure prevents the exposure of any arc flashes. The contactors comply with both IEC and UL standards, including UL's type II coordination requirements.

### General Technical Data

design	magnetic, three phase, with mechanical pre-load contacts for inrush protection
voltage range	$U_{\text{mains}} = 220 \dots 550 \text{ V}$
control voltage	220...250 Vrms
operating temperature	-40°C/D
mounting	DIN hat rail W x H = 35 x 7.5 mm or base mounting lugs for $\varnothing 5 \text{ mm}$ screws
snap-on auxiliary contacts	available on request
standards	IEC EN 60947-4-1, UL508
approval marks	(available on request) UL, CSA

## DIMENSION DRAWINGS

order no.	1301A.CO...			1301A.C7...	
	9-12.5	9-25.0	9-33.3	5-54.0	5-60.0
rated current @50°C	≤18 A	≤36 A	≤48 A	≤87 A	≤92 A
max. kvar 220...240 V	≤6.7	15	20	30	35
max. kvar 400...440 V	≤12.5	25	33.3	54	60
max. kvar 500...550 V	≤18	36	48	78	92
drawing	A	B	B	C	C
permitted switchings/hour	up to 240			up to 100	
contact life (switchings, non-detuned)	200,000			100,000	
preload contacts (obligatory accessory part)	1302A.CO9-00.0			1302A.C75-00.0	
permitted operating temperature	-30 ... +60°C				

Type Range

**A.**

cable cross section  
with ferrule: ≤ 4 mm<sup>2</sup>

**B.**

cable cross section  
with ferrule: ≤ 16 mm<sup>2</sup>

**C.**

cable cross section  
with ferrule: ≤ 35 mm<sup>2</sup>

Dimension Drawings

# THYRISTOR SWITCHES

Other than conventional contactors, our semiconductor-based switches allow for exact determination of the switching moment to the millisecond. This brings about two advantages:

1. Connection of the capacitor exactly at the moment of equal voltage between mains and capacitor element(s): this eliminates inrush effects almost completely without the need for current-limiting resistors, substantially enhancing the operating conditions for the capacitor and resulting in a longer life expectancy.
2. Instantaneous power factor correction for rapidly changing loads: certain reactive loads, e.g. spot welding equipment or elevator systems, call for a high amount of power factor correction for short but very frequent periods. Thyristor switches are capable of multiple switching operations per minute. Since they always switch at zero-voltage-differential (see pt.1), the capacitors do no longer need to be discharged before re-connection, and can sustain substantially higher numbers of connections as compared with conventional magnetic contactors.

### Discharge resistors and thyristor switches:

Thyristor switched capacitors do not require discharge resistors for proper operation. For the purpose of maintenance safety, however, all power capacitors are required to be equipped with bleeding resistors ensuring a discharge below 75V within no more than 3 minutes after disconnection. When selecting the discharge resistors for thyristor-switched capacitors, please consider the following important points:

1. Due to carrier storage effects during switch-off, thyristor switches may charge the capacitor with an overvoltage of up to  $1.43 \times U_{AC}$  (= ca.  $2 \times U_{rms}$ ) at the moment of disconnection. This is unproblematic for ELECTRONICON power capacitors, however frequent switching may overheat and even destroy the bleeding resistors.
2. Certain thyristor switches keep disconnected capacitors constantly charged at maximum AC voltage in order to provide a defined "point of re-entry". This permanent voltage will then be up to 1.41 times above the rated voltage of discharge resistors normally used for "standard" power capacitors!

The resistors integrated in our CAPAGRIP K and CAPAGRIP II terminals are usually rated for the nominal voltage of the connected capacitor and a discharge below 50 V within less than 60 seconds; in the 525 V range, the resistors are dimensioned for such discharge from 480 Vrms (= 680 Vac). They are not suitable for the operation with thyristor switches. You are therefore required to use capacitors from our Heavy Duty ranges with CAPAGRIP L or M terminals instead and select suitable resistor modules from our selection charts on pages 46ff.



**Use resistors with a rated voltage of at least  $2.2 \times U_N$ . As a rule, our 275.106 modules rated 1000 V will be sufficient for equipment in 400 or 440 V mains.**

**Remember that the discharge is relevant for safety aspects only. Select resistor values which serve for a discharge of the capacitors below 75V within 3 or – even better – 5 minutes. This drastically reduces the power dissipation losses of the resistors.**

**Five minutes discharge period is not specified by standard IEC EN 60831. Make sure to place an appropriate warning sticker on capacitors or equipment if selecting resistors this way.**

# CONDENSOTRONIC CT 2000

## YOU'LL BARELY FIND A MORE COMPACT ONE

Immediate compensation of inductive reactive power is very often the only way to cope with disturbances imposed on the mains by huge, rapidly changing inductive loads. Conventional capacitor switching devices with reaction periods of 20...90 seconds cannot comply with such intensive requirements.

The CONDENSOTRONIC thyristor switch module makes reaction times of 1...20 milliseconds possible. The switching is done, practically without reactive effects, at zero voltage level (no voltage between input and output).

CONDENSOTRONIC has a very compact design, convenient connection, integral overheating protection, and LED indication for the switching signal and excessive temperature. For powers above 25kvar, a controllable fan is included.



The CONDENSOTRONIC CT2000 thyristor switch works according to the W3C-2 switching principle, i.e. phase L3 will not be switched.

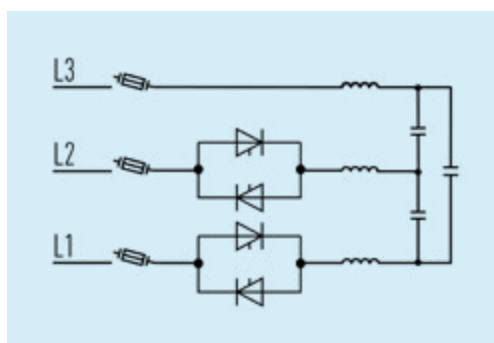

CT 2000  
Switching  
Principle

design	two controlled phases (semi-controlled)
indications	LED
voltage range	$U_{\text{mains}} = 400...525 \text{ V}$ (other voltages on request)
signal voltage	$10 \text{ V} \pm 2 \text{ V DC}$
response time	0.2...15 ms
recovery time	40 ms
max. altitude	1000 m a.s.l.
ambient operating temperature	-10...45°C (up to 65°C with derated current ratings)
storage temperature	-40...85°C
relative humidity	10...95 % (no condensation permitted)
degree of protection	IP20
mounting position	optional

General  
Technical  
Data

# CONDENSOTRONIC CT 2000

## Type Range

type	Q <sub>c</sub> (kvar)	U <sub>N</sub> (V)	I <sub>max</sub> (A)	power losses (W@I <sub>max</sub> )	Fan	dimensions (mm)			weight (kg)	order code
						L	W	H		
CT2000-25-415	25	380 ... 415	52	156	-	145	135	163	3.1	12412.052-10.0
CT2000-25-525	25	400 ... 525	38	132	-	145	135	163	3.1	12522.038-10.0
CT2000-50-415	50	380 ... 415	100	312	x	145	165	174	3.5	12412.100-10.0
CT2000-50-525	50	440 ... 525	78	264	x	145	165	174	3.5	12522.078-10.0

## Dimension Drawings

### CT 2000-25

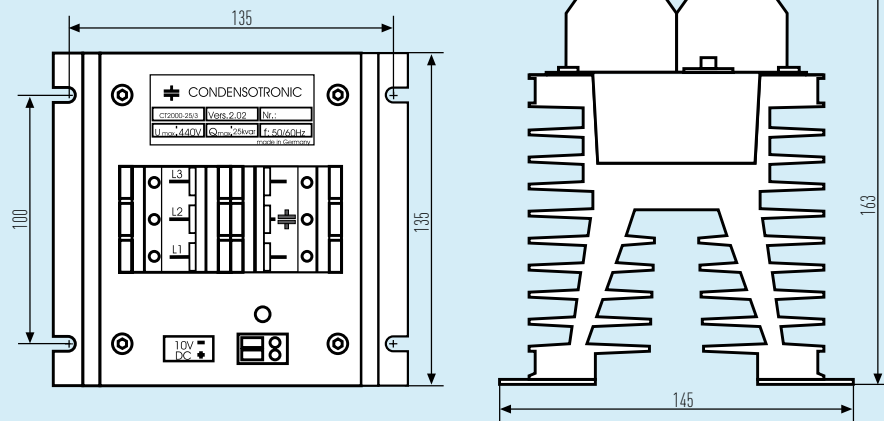

### CT 2000-50

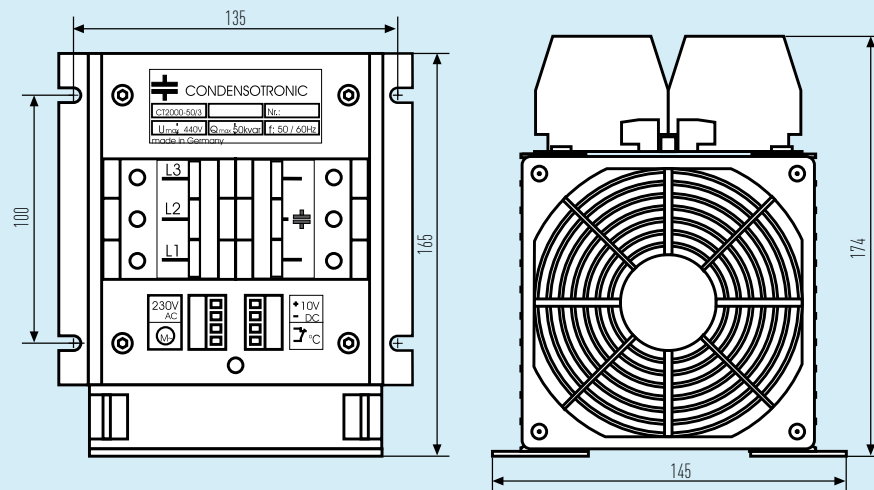

## TS 12-2

### MODERN THYRISTOR SWITCHES FOR YOUR STATIC PFC SYSTEM

The new thyristor switch modules of our TS12-2 series can switch within 20 milliseconds. Other than CT2000, the TS12-2 is kept charged at peak voltage after disconnection. The switching is done, practically without reactive effects, at peak voltage mains level, i.e. when there is no voltage differential between mains voltage and the charge of the capacitor.

The TS12-2-module has a compact design and integral overheating protection. For powers above 50 kvar, a controllable fan is included.



TS12-2 works according to the W3C-2 switching principle, i.e. phase L2 will not be switched.

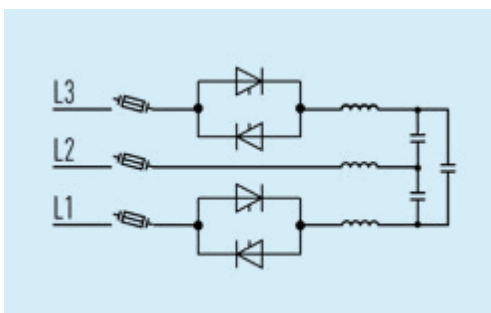

TS12-2  
Switching  
Principle

design	two controlled phases (semi-controlled)
voltage range	$U_{\text{mains}} = U_N = 400 \dots 690 \text{ V}$ (other voltages on request)
control voltage	230 V 50/60 Hz (other voltages on request)
signal voltage	8 - 30 V dc
recovery time	typically 1 period
max. altitude	1000m a.s.l.
ambient operating temperature	-10...45°C (up to 65°C with derated current ratings)
relative humidity	10...95 % (no condensation permitted)
degree of protection	IP10
mounting position	optional

General  
Technical  
Data

# TS 12-2

## Type Range

type	U <sub>N</sub> (V)	Q <sub>c</sub> (kvar)	I <sub>N</sub> (A)	max. I <sub>N</sub> (A)	power losses (W@I <sub>max</sub> )	Fan	dimensions (mm)		weight (kg)	order code
							L <sub>1</sub>	H <sub>1</sub>		
TS12-2-36-400	400	25	36	47	93	-	-	215	4.3	12402.036-00.0
TS12-2-72-400	400	50	72	93	165	-	-	215	4.3	12402.072-00.0
TS12-2-109-400	400	75	109	141	283	x	260	215	5.6	12402.109-00.0
TS12-2-144-400	400	100	144	187	341	x	260	215	5.6	12402.144-00.0
TS12-2-33-440	440	25	33	43	74	-	-	215	4.3	12442.033-00.0
TS12-2-66-440	440	50	66	86	153	-	-	215	4.3	12442.066-00.0
TS12-2-99-440	440	75	99	129	262	x	260	215	5.6	12442.099-00.0
TS12-2-131-440	440	100	131	170	305	x	260	215	5.6	12442.131-00.0
TS12-2-30-480	480	25	30	39	67	-	-	215	4.3	12482.030-00.0
TS12-2-60-480	480	50	60	78	139	-	-	215	4.3	12482.060-00.0
TS12-2-90-480	480	75	90	117	235	x	260	215	5.6	12482.090-00.0
TS12-2-120-480	480	100	120	156	276	x	260	215	5.6	12482.120-00.0
TS12-2-150-480	480	125	150	195	356	x	260	215	5.6	12482.150-00.0
TS12-2-72-525	525	65	72	93	159	-	-	215	4.3	12522.072-00.0
TS12-2-144-525	525	130	144	187	325	x	260	215	5.6	12522.144-00.0
TS12-2-42-690	690	50	42	54	104	-	-	250	4.6	12692.042-00.0
TS12-2-84-690	690	100	84	109	207	x	260	250	5.9	12692.084-00.0

## Dimension Drawings

### reference example with integrated fan

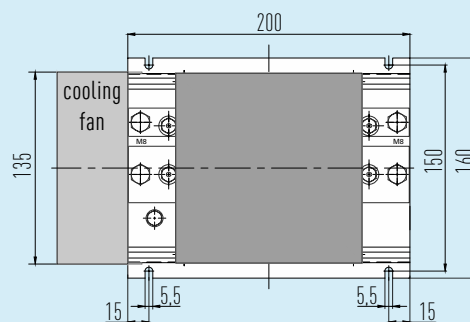
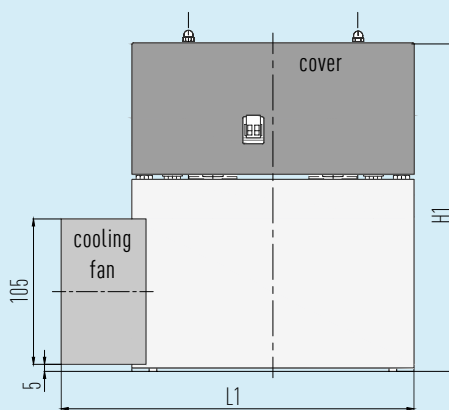



# DISCHARGE DEVICES

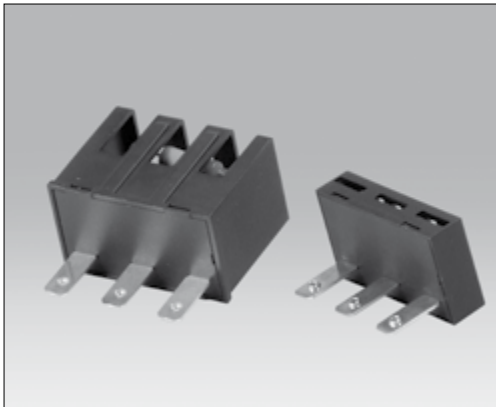

## Resistor Modules

Capacitors with CAPAGRIP K and CAPAGRIP II terminals are equipped with discharge resistors for a discharge from their highest nominal voltage rating to less than 50 V within < 60 seconds. For capacitors with CAPAGRIP L and M we offer separate resistor modules. The correct size of the module to be applied can be selected from the data charts on pages 47f based on applied voltage, required discharge period, and capacitance to be discharged.

Alternatively, the resistors to be used for a given capacitance and operating voltage can be calculated by means of the following formula:

**three-phase:** 
$$R \leq \frac{t}{k \times C_T \times \ln \frac{U_B \times \sqrt{2}}{U_E}}$$

**single-phase:** 
$$R \leq \frac{t \times 1.5}{C_{total} \times \ln \frac{U_B \times \sqrt{2}}{U_E}}$$

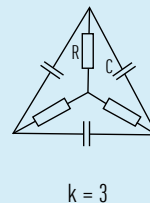
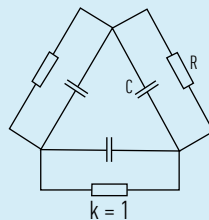

t ... Discharge period in (s)	U <sub>B</sub> ... Operating voltage
C <sub>T</sub> ... Partial capacitance of one phase	U <sub>E</sub> ... Maximum permissible voltage after period t
C <sub>total</sub> ... Total capacitance	R ... Module resistance value

In all cases, the closest smaller discharge module available shall be applied.

**The discharge resistors may become very hot (up to 200°C) during continuous operation!**  
**For design L/M only: Remove the lid of the discharge module if applying protective caps to the capacitors!**



## Sets for CAPAGRIP™ L & M Capacitors (Protection: IP20)

CAPAGRIP™ resistor modules can be connected to single capacitors as well as to groups of parallel units. Both type 1 and 2 are equally compatible with CAPAGRIP™ L or M terminals.

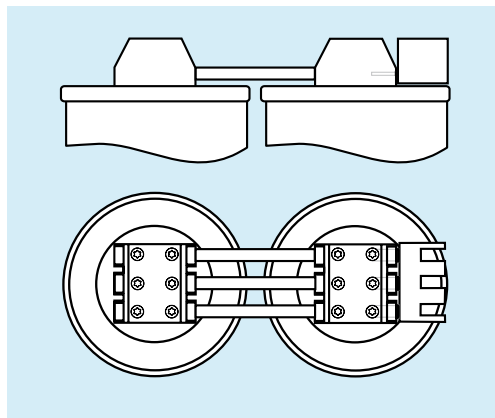
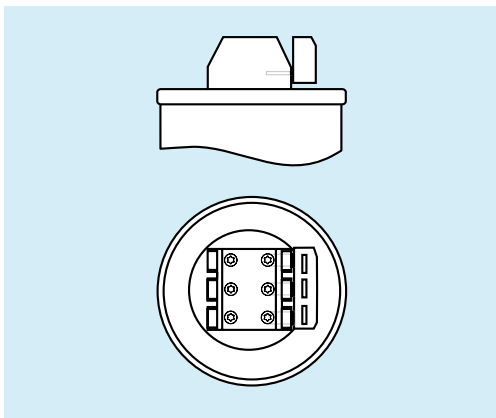

# DISCHARGE DEVICES

Type 1

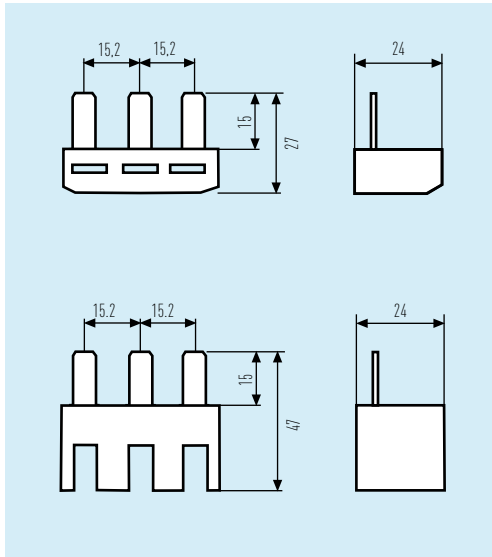

Type 2

$U_{\max}$ (V)	$R_N$ (k $\Omega$ )	module type	selection code	order code
1000	3 Y 300	2	(1)	275.106-10300
1000	3 Y 180	2	(2)	275.106-10180
850	3 Y 120	2	(3)	275.106-10120
760	3 $\times$ 300	1	(4)	275.100-10300
720	3 $\times$ 180	2	(5)	275.105-10180
600	3 $\times$ 180	1	(6)	275.100-10180
600	3 $\times$ 120	2	(7)	275.105-10120
480	3 $\times$ 120	1	(8)	275.100-10120
530	3 $\times$ 100	2	(9)	275.105-10100
480	3 $\times$ 82	2	(10)	275.105-10082
400	3 $\times$ 82	1	(11)	275.100-10082
440	3 $\times$ 68	2	(12)	275.105-10068

### Selection Charts

The selection charts state the maximum capacitance per voltage level which can be discharged with each resistor module:

1. Select the line of your **operating** voltage. Mind that in detuned systems, the actual voltage at the capacitor is higher than the rated mains voltage.
2. Look for the column with the capacitance which is closest to your capacitor. Look up BLACK figures if you want to discharge below 50 V within no more than 60 seconds. Look up BLUE figures if you want a discharge below 75 V within 3 minutes. Go for GREY figures if 5 min discharge is sufficient.
3. Determine the resistor module to be ordered in the head of the column.

# DISCHARGE DEVICES

Selection Matrix for CAPAGRIP™ Resistor Modules (3ph. star connected)

capacitor voltage (V)		C <sub>max</sub> to be discharged (μF)											
U <sub>max</sub>	U <sub>AC</sub>	(1)	(2)	(3)	(4)	(5)	(6)	(7)	(8)	(9)	(10)	(11)	(12)
230	325	3×36	3×59	3×89	3×107	3×178	3×178	3×267	3×267	3×320	3×391	3×391	3×471
		3×136	3×227	3×341	3×409	3×682	3×682	3×1022	3×1022	3×1227	3×1496	3×1496	3×1804
		3×227	3×379										
280	395	3×32	3×54	3×81	3×97	3×161	3×161	3×242	3×242	3×290	3×354	3×354	3×426
		3×120	3×200	3×301	3×361	3×601	3×601	3×902	3×902	3×1082	3×1319	3×1319	3×1591
		3×200	3×334										
400	565	3×27	3×46	3×69	3×82	3×137	3×137	3×206	3×206	3×247	3×302	3×302	3×364
		3×99	3×165	3×247	3×297	3×495	3×495	3×742	3×742	3×891	3×1086	3×1086	3×1310
		3×165	3×275										
415	585	3×27	3×45	3×68	3×81	3×135	3×135	3×203	3×203	3×244	3×297		3×358
		3×97	3×162	3×243	3×292	3×486	3×486	3×729	3×729	3×875	3×1067		3×1287
		3×162	3×270										
440	620	3×26	3×44	3×66	3×79	3×132	3×132	3×198	3×198	3×238	3×290		3×350
		3×95	3×158	3×236	3×284	3×473	3×473	3×709	3×709	3×851	3×1037		3×1251
		3×158	3×263										
480	680	3×26	3×43	3×64	3×77	3×128	3×128	3×192	3×192	3×230	3×281		
		3×91	3×151	3×227	3×272	3×454	3×454	3×681	3×681	3×817	3×996		
		3×151	3×252										
525	740	3×25	3×41	3×62	3×74	3×124	3×124	3×185		3×222			
		3×87	3×145	3×218	3×262	3×436	3×436	3×654		3×785			
		3×145	3×242										
600	850	3×24	3×39	3×59	3×71	3×118	3×118	3×177					
		3×82	3×137	3×206	3×247	3×412	3×412	3×618					
		3×137	3×229										
690	975	3×22	3×37	3×56	3×67	3×112							
		3×78	3×130	3×195	3×234	3×390							
		3×130	3×217										
760	1075	3×22	3×36	3×54	3×65								
		3×75	3×125	3×188	3×225								
		3×125	3×209										
800	1130	3×21	3×36	3×53									
		3×74	3×123	3×184									
		3×123	3×205										
850	1200	3×21	3×35	3×52									
		3×72	3×120	3×180									
		3×120	3×200										
1000	1415	3×20	3×33										
		3×68	3×114										
		3×114	3×189										

C<sub>max</sub> for discharge < 50 V within 1 min  
 C<sub>max</sub> for discharge < 75 V within 3 min  
 C<sub>max</sub> for discharge < 75 V within 5 min\*

\*Recommended for thyristor-switched equipment.  
 NOTE: Warning about 5 min discharge time should be placed on the equipment.

## EL-DR DISCHARGE REACTOR 40E.003-60002

The increasing demand for shorter discharge periods cannot be satisfied by traditional discharge means (fixed resistors). The installation of additional fast discharge resistors at the capacitor contactor results in an increase in material and installation costs. Our discharge reactor replaces the compulsory fixed resistors and additional rapid discharge resistors, and at the same time it reduces the heat dissipation losses inside the capacitor bank. It further avoids additional heating of the capacitor terminals by standard discharge resistors.



**Discharge reactors must NOT be used in combination with thyristor switches. Frequent switching and the charging function of many switches will damage the reactor.**

### General Technical Data

design	two controlled phases (semi-controlled)
construction	dual reactor with iron core in plastic housing
DC resistance per coil	7600 Ohm
duty cycle	continuous operation
rated voltage	230 ... 600 V 3ph, 50/60Hz
capacitor ob e discharged	5 ... 50kvar
connection	direct mounting on capacitor terminal (design L/M)
vibration stress	not permitted
dissipation losses	< 1W
ambient temperature	max. 40° C
degree of protection	IP20
dimensions W × H × D	58 × 49 × 39 mm
weight	290 g
insulation	class B (135°C)
standard	IEC 61558-2-20
CE conformity	2014/35/EU Low-Voltage Directive

### Dimension Drawings

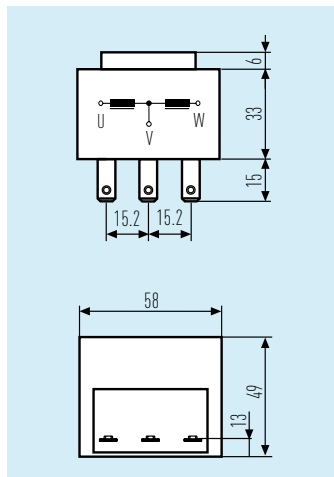

Q <sub>c</sub> (kvar)	permitted no. of discharges/min at 40°C		discharge period (sec)					
	400...525 V	230 V/600 V	230 V	400 V	440 V	480 V	525 V	600 V
12.5	5	4	12	5	4	4	4	2.6
25	4	3	24	10	9	8	7	5
30	3	2	-	12	10	9	8	6
50	2	1	-	20	17	15	14	10.5

## ACCESSORY PARTS

### Protective Blank for CAPAGRIP™ M Terminal (IP20)

Type M terminals are designed for accepting 50mm<sup>2</sup> cables. If one side of the terminal block is not used, then this blank must be fitted to maintain the IP20 rating.

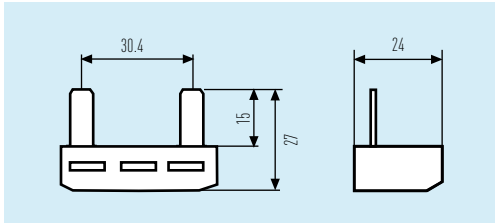

**Order code:**  
275.100-10000 (10/box.)

## DETUNING REACTORS

The growing use of power electronic devices is causing an increasing level of harmonic distortion in the electrical system which very often leads to problems with capacitor installations. This is the reason why more and more energy suppliers demand the installation of detuned capacitors.

A detuned capacitor performs the function of power factor improvement whilst preventing any amplification of harmonic currents and voltages caused by resonance between capacitors and inductances in the electrical system.

By adding an appropriately rated series reactor to the power capacitor, both elements form a **resonating circuit with its resonant frequency below the lowest order harmonic** in the system (usually the 5th). All frequencies above this resonant frequency now see this circuit as inductive hence eliminating the possibility of dangerous resonances being set up between the capacitors and system inductances (provided the reactor has been dimensioned properly).

It has to be ensured, however, that non-detuned capacitors and capacitors with detuning reactors are never operated in the same mains. Such combination may cause unforeseeable interactions and equalising currents leading to damage and destruction of capacitors, reactors, and other components.

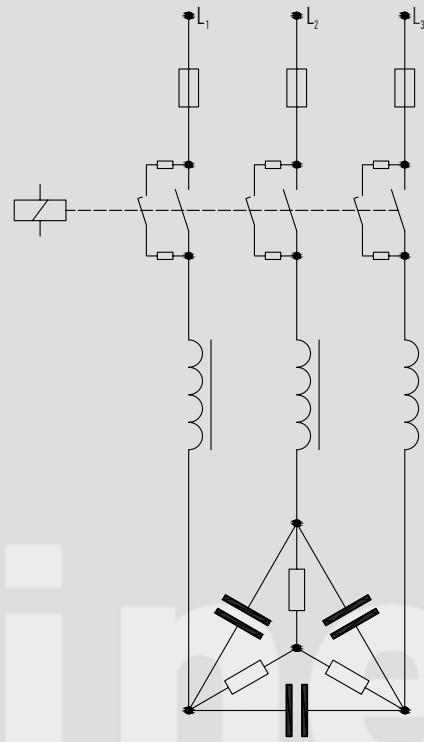

# DETUNING REACTORS

## PROTECTING CAPACITORS

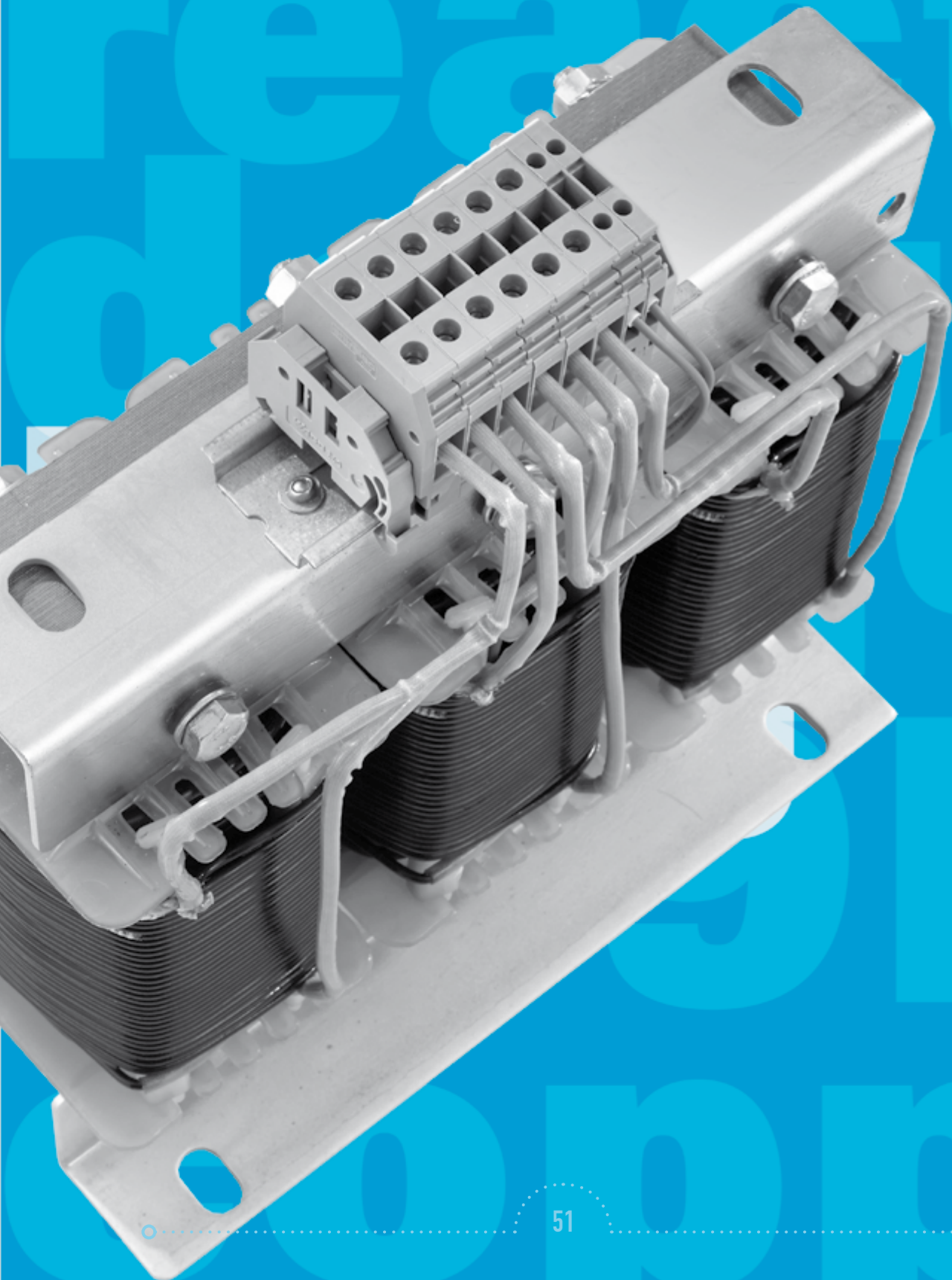

# DETUNING REACTORS

## Design features

Our filter reactors are made of **high-class transformer sheets** and **copper wire or aluminium band**.

They are dried and impregnated in a vacuum with environmentally friendly, low-styrole resin which ensures they can withstand high voltages, have low noise levels, and offer a long operating life.

Depending on their rated power, the reactors are provided with either terminal blocks or terminal lugs/cables. The connection of the aluminium reactors is made through copper terminals as well, which are reliably connected with the aluminium band by a special, well-proven welding method.

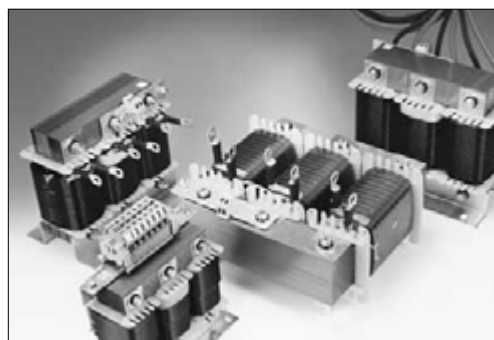

High-class iron cores with multiple air gaps as well as a staid designing approach guarantee **high current linearity** and **low heat dissipation losses**, at the same time allowing for compact dimensions and competitive cost. Compared with low-end reactors, our FK-Dr may save up to 100 Watts of heat dissipation losses per piece, a very important factor for the long-term operational cost (and amortisation) of the equipment.

## High insulation class or low temperature rise?

Other than certain manufacturers which take special pride in offering their reactors with insulation class ratings for operation at temperatures of up to 165°C or even beyond, we focus on the operating environment of the the application's key component: the capacitor. In most cases, reactors are placed in close vicinity of the capacitor, and should therefore not serve as a destructive heat source. The conservative layout of our reactors is to limit the maximum temperature of the reactor to 115°C under rated operating conditions. An integrated reversible thermal switch allows external monitoring for disconnection of the reactor in the event of impermissible buildup of heat (>125°C).

## How to avoid ferro-resonance

Commercial pressures and the desire for ever smaller switchgear dimensions lead to an increasingly intense utilisation of systems and components. Even the detuning reactors have become more compact, which has been accompanied by a reduction of their internal resistance.

Despite excellent linearity of inductance at high currents - usually the most important criterion when evaluating reactors - problems may occur in operation under unknown mains conditions. e.g. insufficient damping (low impedance) by upstream switchgear components, even at relatively low levels of harmonic distortion. Due to the magnitude of the initial switching current, the inductance of the reactor may break down to a fraction of its nominal value. In these cases, the core becomes saturated; strong audible humming and currents exceeding the rated current can occur. This phenomenon is also called **Ferro-resonance**.

As the use of adequately sized reactors with higher load capability is usually ruled out for cost and space considerations, the use of **capacitor contactors with inrush protection** is recommended in all cases where the mains conditions are not known exactly. These can provide a damping effect which substantially exceeds that achieved by adaptation of the reactor dimensions, and at a much reduced cost.

It should be noted that, even when using capacitor contactors with inrush protection, sufficient current linearity of the reactor must be provided in accordance with its operating conditions.



# DEFINITIONS AND SELECTION CRITERIA

## Rated Inductance $L_N$

Inductance rating of the reactor, measured at rated current  $I_N$ , in mH (Milli-Henry). Mean value across the three phases.



## Rated Voltage $U_N$

Root mean square value of the permissible value of sinusoidal AC voltage in continuous operation (mains voltage). The rated voltage of the reactors indicated in the data charts and the permissible overvoltage limits specified in IEC 60831 and DIN EN 50160 must not be exceeded even in cases of malfunction.



## Capacitor Voltage $U_C$

Required voltage strength of the capacitor. The series connection of capacitor and reactor causes a voltage rise at the capacitor terminals as described by the following formula which must be considered when selecting a capacitor for the application.



$$\begin{aligned} U_N &= 400 \text{ V} \\ p &= 7 \% \end{aligned}$$

$$U_C = \frac{U_N}{\left(1 - \frac{p}{100\%}\right)} = 430.1 \text{ V}$$

The capacitor to be selected must have a voltage strength of at least 430 V.



Example

## Detuning Factor $p$

Ratio between the reactances of reactor  $X_L$  and corresponding capacitor  $X_C$  (in %).

$$p = 100\% \cdot \frac{X_L}{X_C}$$



## Series Resonance Frequency $f_r$

The detuning factor determines the series resonance frequency between reactor and capacitor which in turn is important for the blocking and filtering effect.

$$f_r = f_N \cdot \sqrt{\frac{100\%}{p}}$$



Note: In certain countries, it is common to describe the Detuning factor as the ratio of the detuning frequency in relation to the basic frequency (Hz) of the supply.

The standard reactors listed in this catalogue have been designed for common detuning factors and resonance frequencies as shown in chart 11:

Detuning factor $p$	$f_r$ -Ratio	Resonance frequency $f_r$
5.67 %	4.2 H	252 Hz
6 %	4.1 H	245 Hz
7 %	3.8 H	227 Hz

chart 11

## Rated Power of the Detuned System $Q_{LC}$

Care must be taken when stating the reactor power in order to avoid misunderstanding. As a rule, the rated power of a reactor does not describe its real reactance but either the reactive power of the capacitor to be detuned, or the total output of the entire LC-circuit at rated system voltage  $U_N$ .



There are two principal approaches which are described in detail on the following pages.

# DEFINITIONS AND SELECTION CRITERIA



## I. Non-adapted Rating:

The non-adapted reactor is matched to a power capacitor with standard rating at system voltage. This allows for use of capacitors "off the shelf". However, with the increased output of kvar due to voltage rise inside the LC circuit, more power output is installed than actually required: the kvar output of a capacitor depends on the voltage it is charged with, and at higher voltage, equal capacitance delivers more kvar (in the example below: 26.9 instead of 25 kvar). In this case, the rated power of the capacitor is used to define the reactor rating.



**Caution: Bear in mind that the capacitors to be detuned will be exposed to increased voltage; excessive voltage load may lead to reduced life or even failure or destruction of the capacitor!**



**Check capacitance and general state of the capacitors before adding detuning reactors to existing non-detuned systems as these may have been harmed by their previous operation without reactor protection!**



Example  
Calculation

Capacitor 265.278-609600 (page 28) with 25kvar 480V 60Hz  $3 \times 96\mu\text{F}$  (288 $\mu\text{F}$ ) shall be detuned to 227Hz ( $p = 7\%$  or 3.8H).

### Step 1: Determination of the reactor

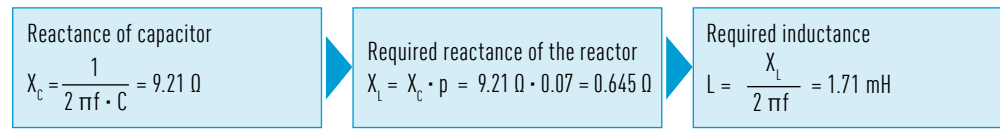

→ 444.126+48D8A0 "Fk-Dr 25/480/60/7/D" (page 63)

### Step 2: Calculation of resulting PFC current and net kvar output into the mains

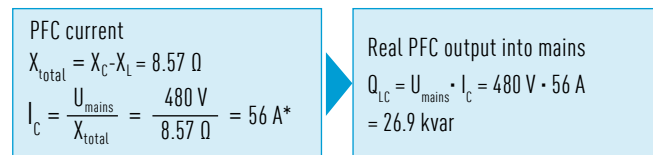

Selection  
from catalogue

### Step 1: Determination of the reactor

Alternatively, reactors matching the most common capacitor ratings can be selected directly from our data charts of reactors with "non-adapted rating" (page 62/63):

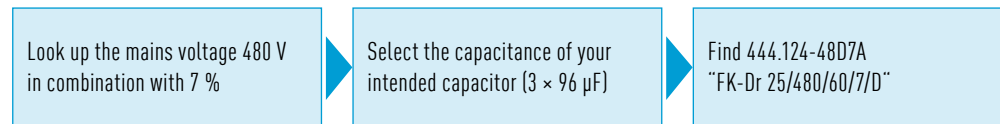

### Step 2: Determination of net kvar output into the mains and calculation of PFC current

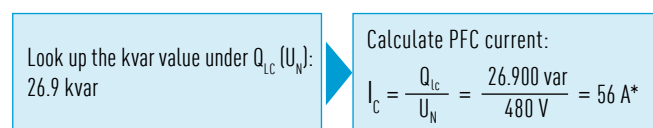

(\*current over three phases = phase current  $\cdot \sqrt{3}$ )

# DEFINITIONS AND SELECTION CRITERIA

## II. Adapted Rating:

The adapted reactor is designed to create – in combination with a specially sized capacitor - exactly the desired output of reactive power, allowing for the internal voltage rise inside the resonating circuit.

Advantage: The exact power is installed as required by the customer, and switching devices are stressed less.



25kvar 480V 60Hz to be detuned to 227Hz (p = 7%)



Example

Calculation

### Step 1: Calculation of the capacitor

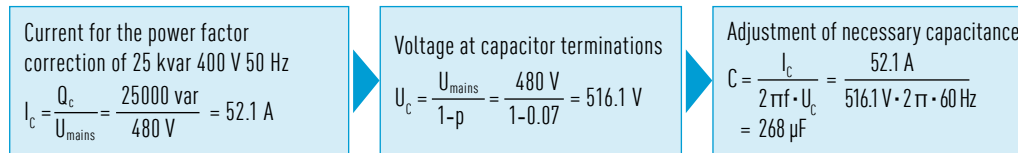

268µF = 3 × 89µF 265.286-708900 “27.7 kvar 525V 60Hz” (page 29)

### Step 2: Calculation of the reactor

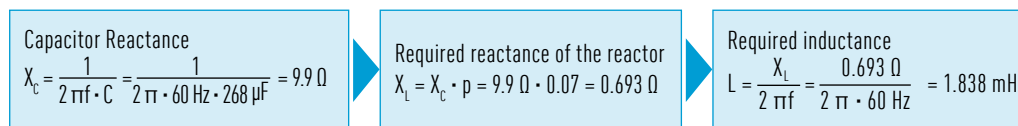

→ 444.125-4837A0 “Fk-Dr 25/480/60/7/Dla” (page 64)

### Step 1: Determination of the reactor

Alternatively, reactors matching the most common capacitor ratings can be selected directly from our data charts of reactors with “adapted rating” (page 64):

Selection

from catalogue

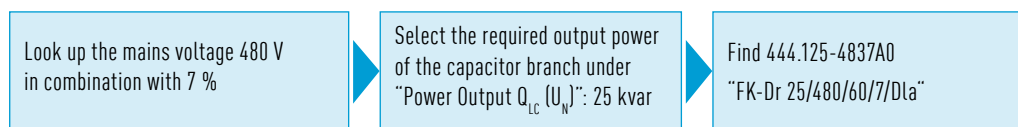

### Step 2: Determination of the matching capacitor

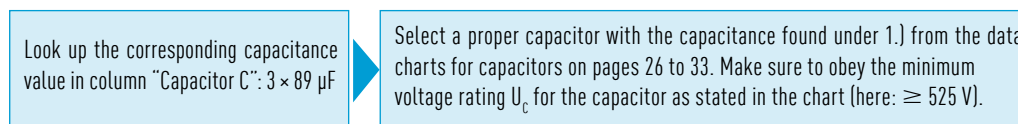

## DEFINITIONS AND SELECTION CRITERIA



### Dissipation Power $P_{\text{eff}}$

Sum of all iron-, copper-, and stray field losses at max. specified overvoltage and harmonic content. Depending on the detuning factor, the effective dissipation power of our reactors is between 4 and 6 W/kvar.



### Rated Current (also: Fundamental Current) $I_N$

RMS value of the current – caused by the series-connected capacitor – at rated voltage and frequency, excluding harmonic distortion, switching transients, and tolerance of capacitance.



### RMS Current $I_{\text{eff}}$

Current load on the reactor in permanent operation, caused by the fundamental wave plus harmonics in the system. For all data given in this catalogue, we are presuming a 10 % increase of the fundamental current  $I_N$ , resulting from voltage tolerances as permitted by DIN EN 50160:  $I_{\text{eff}} = \sqrt{(I_1^2 + I_3^2 + I_5^2 + \dots + I_n^2)}$   $I_1 = 1.1 \cdot I_N$



### Maximum Current Rating $I_{\text{lin}}$ and Current Linearity

Maximum current, up to which the inductance of the reactor remains “linear”, i.e. does not decrease by more than 5 % below its rated inductance. This maximum current is specified in the data charts as a multiple K of the fundamental current:

$$I_{\text{lin}} = K \cdot I_N \quad (L_{\text{lin}} \geq 0.95 L_N) \quad K \dots \text{overcurrent factor}$$

Exceeding  $I_{\text{rms}}$  or  $I_{\text{lin}}$  will cause increased power losses inside the reactor and may result in its thermal destruction. We recommend thermal monitoring of the reactors by means of the integrated temperature switch, or the use of switching devices with overcurrent relays in the capacitor circuit, to protect against overloads.



### Ambient Operating Conditions

Permissible ambient conditions for safe operation of the reactor. For our reactors, we specify the climate category in the data charts as “CTT” in accordance with DIN EN 50019 and DIN EN 60934/IEC 60439-1:

C	climatic areas	TT	$\Theta_{\text{ambient}}$	$\Theta_{\text{average in 24 h}}$
T	„Moderate climate”	45	-5 ... 45 °C	≤ 40 °C
		50	-5 ... 50 °C	≤ 45 °C
		55	-5 ... 55 °C	≤ 50 °C

chart 12

Under these conditions, the temperature of our low loss reactors does not exceed 115°C which is an important advantage for the capacitors and all other components in the installation. Please consult us if you require reactors for more severe ambient conditions.

### Insulation Class

Maximum permitted operating temperature for the insulation materials used in the reactor. Thanks to careful design and the use of high-class materials, the operating temperature of our low-loss reactors does not exceed 115°C when operated within specification. Our standard rating of insulation class B (135°C) should therefore be sufficient for the majority of your operating environments. Reactors with insulation class F or higher are available as an option on request.



### Temperature Switch

response temperature	125°C
voltage	250 V (<6.3 A) ... 500 V (<2 A)
tolerance	± 5 K
terminal	screw clamp 0.75 mm <sup>2</sup>

All reactors are provided with a separate screw terminal for the temperature switch (NC – normally closed) which is located inside the central coil.

## DATA CHARTS

rated voltages	230...480 V 60 Hz
design	three phase
tolerance of inductance	- 3 ... + 3 % (mean value across three phases)
terminals	terminal blocks, cable lugs temperature-proof flexible cables available on request
winding material	aluminium band or copper wire
core material	low loss iron sheets
safety device	thermal switch
impregnant	polyester resin Class F
insulation class	class B (higher classes available on request)
protection class	IP00 (indoor mounting)
current linearity	see data charts
permitted harmonic load (continuous operation)	$U_3 = 0.5 \% U_N$ $U_5 = 6 \% U_N$ $U_7 = 5 \% U_N$ $U_{11} = 3.5 \% U_N$ $U_{13} = 3 \% U_N$
insulation voltage winding to core	3 kV
max. relative humidity	95 %
temperature class	see data charts
cooling	natural
altitude	4000 m.a.s.l.
statistical life expectancy	> 200 000 h (permitted failure rate $\leq 3 \%$ )
standards	IEC EN 61558-2-20:2011, VDE 0570-2, IEC 60076-6:2007, UL508, C22.2 No.14
approval marks	 for selected types

General  
Technical  
Data

DATA CHARTS

### CE Conformity

All reactors listed in this catalogue comply with the relevant regulations and guidelines of the European Union: 2014/35/EU (Low-Voltage Directive)



This is proven by the technical documentation and compliance with the following standards: IEC EN 61558-2-20:2011, IEC EN 60076-6:2007

# DIMENSION DRAWINGS

Dimension Chart

Code	L (mm)	H (mm)	Design A B (mm)	Design B B (mm)	pcs./pallet	pallet height (mm)
A1	155	140	78	-	48	350
A2	155	140	92	85	36	350
B1	190	165	82	87	33	350
B2	190	165	92	97	27	350
B3	190	165	102	107	24	350
C1	240	215	121	112	20	550
C2	240	215	131	122	20	550
C3	240	215	141	132	18	550
C4	240	215	151	142	16	550
C5	240	215	155	146	12	550
D2	300	265	165	139	10	550
D3	300	265	177	152	10	550
D4	300	265	192	167	10	550
D5	300	265	203	178	8	550
F3	300	190	166	-	10	350
F4	300	190	180	155	10	350
F5	300	190	191	166	10	350
F6	300	190	201	175	10	350
G1	240	255	121	112	16	550
G2	240	255	153	144	12	550
H1	420	370	188	190	8	600
I1	300	315	166	141	10	600

DIMENSION DRAWINGS

## Type 1

### Connection Type 1



Type 1: Screw terminal block, 10 mm<sup>2</sup>  
Available with copper windings only

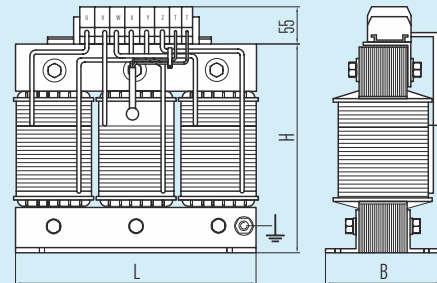

# DIMENSION DRAWINGS

## Connection Type 2

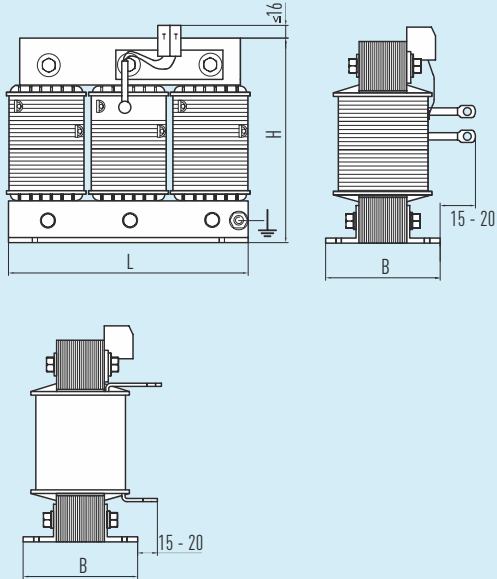

Type 2: Cable lug (tinned copper)  
Available with copper or aluminium windings

Type 2

## Connection Type 3

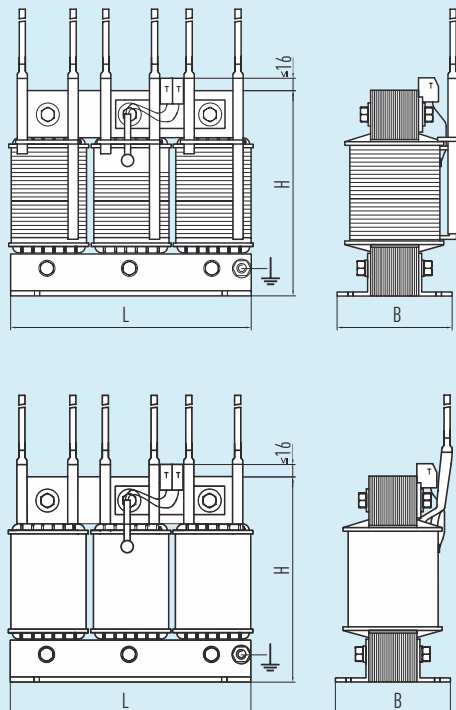

Type 3: Flexible cable,  
temperature proof up to 140°C,  
length: 500 or 800 mm  
Available with copper or aluminium windings

Type 3

# DIMENSION DRAWINGS

## Design A

### Mounting Design A



Standard version  
with base mounting bracket

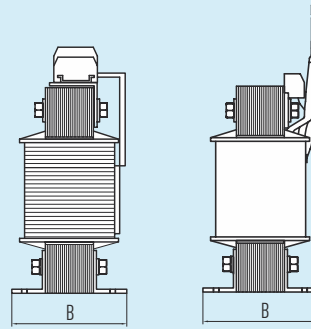
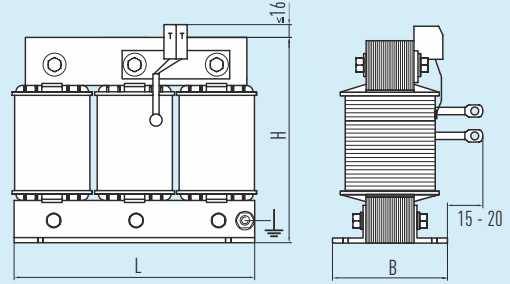

## Design B

### Mounting Design B

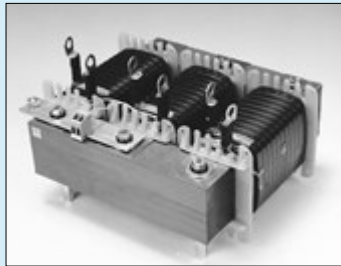

Four threaded bolts (M6i or M8i)  
for lateral mounting

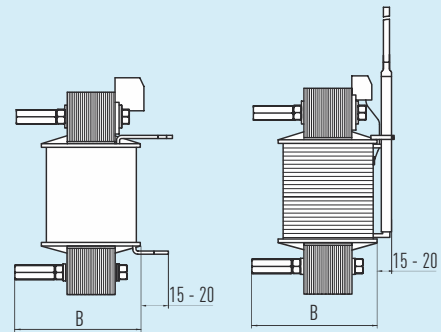
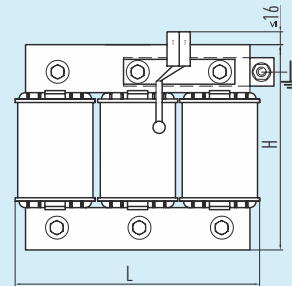



# DIMENSION DRAWINGS

## Design 2in1

This very compact design combines two partial powers in one unit. They can be operated independently from each other.

## Design 2in1

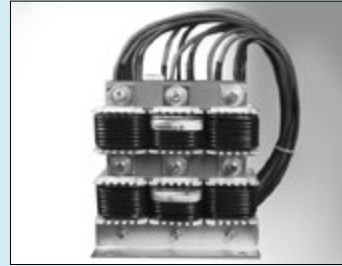
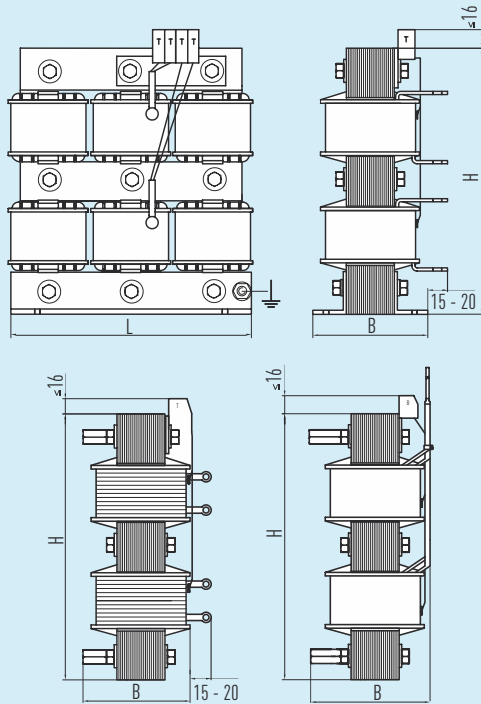

Available terminals: type 2 and 3.  
Available designs: A and B.

## FK-Dr

### NON-ADAPTED RATING (D)

#### 5.67 %, 7 %

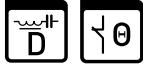

Reactors for standard capacitors (non-adapted rating)

Power Output $Q_{LC} (U_N)$ (kvar)	Capacitor $C_N$ ( $\mu$ F)	type designation FK-Dr ...	winding	$L_N$ (mH)	$I_{eff}$ (A)	Reactor / Drossel			order code (standard version)	connection / design					
						Temp. class	size (S.pg. 50)	weight (kg)		1	2	3	A	B	
$U_N$ 230 V		$U_C \geq 250$ V		$p = 5.67$ % [252 Hz]		$I_{lin} 1.8 \dots 2.2 I_N$									
5.3	3 × 84	5/230/60/5.67/D	Cu	3 × 1.59	3 × 17	T55	B1	5.3	407.093-24B900	○		●	●	○	
8	3 × 125	7.50/230/60/5.67/D	Cu	3 × 1.06	3 × 26	T55	B1	6	417.093-24B905	○		●	●	○	
10.6	3 × 167	10/230/60/5.67/D	Cu	3 × 0.8	3 × 35	T55	B2	7.7	425.094-24B900	○	○	●	●	○	
13.3	3 × 209	12.5/230/60/5.67/D	Cu	3 × 0.64	3 × 44	T45	B2	8.6	428.094-24B905	○	○	●	●	○	
15.9	3 × 251	15/230/60/5.67/D	Cu	3 × 0.53	3 × 52	T55	C1	12.4	433.124-24B900		○	●	●	○	
21.2	3 × 333	20/230/60/5.67/D	Cu	3 × 0.4	3 × 70	T45	C1	14.4	440.124-24B900		○	●	●	○	
21.2	3 × 333	20/230/60/5.67/D	Alu	3 × 0.4	3 × 70	T55	C3	15.5	440.126+24B800		●	○	●	○	
26.5	3 × 418	25/230/60/5.67/D	Alu	3 × 0.32	3 × 87	T55	C4	18.2	444.127+24B800		●	○	●	○	
53	3 × 836	50/230/60/5.67/D	Alu	3 × 0.16	3 × 174	T55	D3	31	458.157+24B800		●	○	●	○	
$U_N$ 230 V		$U_C \geq 250$ V		$p = 7$ % [227 Hz]		$I_{lin} 1.8 I_N$									
10.8	3 × 167	10/230/60/7/D	Cu	3 × 0.98	3 × 32	T55	B2	7.3	425.094-24D7A0	○	●	○	●	○	
13.4	3 × 209	12.5/230/60/7/D	Cu	3 × 0.79	3 × 40	T45	B2	7.6	428.094-24D7A	○	●	○	●	○	
16.1	3 × 251	15/230/60/7/D	Cu	3 × 0.65	3 × 47	T55	C6	11.1	433.225-24D7A0	○	●	○	●	○	
21.5	3 × 334	20/230/60/7/D	Alu	3 × 0.49	3 × 63	T55	C1	12	440.124+24D8A0		●	○	●	○	
26.9	3 × 418	25/230/60/7/D	Cu	3 × 0.39	3 × 79	T55	C2	16.1	444.125-24D7A		●	○	●	○	
32.3	3 × 502	30/230/60/7/D	Alu	3 × 0.33	3 × 95	T55	F3	20.4	450.256+24D8A0		●	○	●	○	
43	3 × 666	40/230/60/7/D	Cu	3 × 0.25	3 × 127	T50	F4	26	454.258-24D7A0		●	○	●	○	
53.8	3 × 836	50/230/60/7/D	Cu	3 × 0.2	3 × 158	T50	D2	29.8	458.156-24D7A		●	○	●	○	
$U_N$ 440 V		$U_C \geq 480$ V		$p = 7$ % [227 Hz]		$I_{lin} 1.8 I_N$									
13.4	3 × 58	12.5/440/60/7/D	Cu	3 × 2.88	3 × 20	T45	B1	7	428.093-44D7A	○	●	○	●	○	
26.9	3 × 115	25/440/60/7/D	Cu	3 × 1.44	3 × 39	T45	C1	14.1	444.124-44D7A		●	○	●	○	
53.8	3 × 230	50/440/60/7/D	Alu	3 × 0.72	3 × 83	T45	F5	29.1	458.259+44D8A0		●	○	●	○	
80.7	3 × 345	75/440/60/7/D	Cu	3 × 0.48	3 × 118	T45	D3	37	468.157-44D7A		●	○	●	○	

- standard design
- other available options

Other ratings, linearities and detuning factors are available on request.

## FK-Dr NON-ADAPTED RATING (D) 5.67 %, 6 %, 7 %



Reactors for standard capacitors (non-adapted rating)

Power Output $Q_{LC} (U_N)$ (kvar)	Capacitor $C_N$ ( $\mu$ F)	type designation FK-Dr ...	winding	$L_N$ (mH)	$I_{eff}$ (A)	Reactor / Drossel			order code (standard version)	connection / design					
						Temp. class	size (S.pg. 58)	weight (kg)		1	2	3	A	B	
<b><math>U_N</math> 380 V    <math>U_c \geq 410</math> V    <math>p = 6\%</math> [245 Hz]    <math>I_{lin} 1.8 I_N</math></b>															
6.7	3 × 38	6.25/380/60/6/D	Cu	3 × 3.68	3 × 13	T55	B1	5.8	412.093-38C6A	●		○	●	○	
13.3	3 × 77	12.5/380/60/6/D	Cu	3 × 1.8	3 × 25	T45	B1	6.6	428.093-38C7A0	○	●	○	●	○	
26.6	3 × 154	25/380/60/6/D	Cu	3 × 0.9	3 × 51	T45	C1	13.4	444.124-38C7A0		●	○	●	○	
53.2	3 × 308	50/380/60/6/D	Cu	3 × 0.46	3 × 101	T45	F4	26.6	458.258-38C7A		●	○	●	○	
53.5	3 × 308	50/380/60/6/D	Alu	3 × 0.46	3 × 102	T45	F5	27.7	458.259+38C8A0		●	○	●	○	
<b><math>U_N</math> 380 V    <math>U_c \geq 410</math> V    <math>p = 7\%</math> [227 Hz]    <math>I_{lin} 1.8 I_N</math></b>															
13.4	3 × 77	12.5/380/60/7/D	Cu	3 × 2.15	3 × 24	T45	B2	8	428.094-38D7A	○	●	○	●	○	
26.9	3 × 154	25/380/60/7/D	Cu	3 × 1.07	3 × 48	T45	C1	14.6	444.124-38D7A		●	○	●	○	
53.8	3 × 308	50/380/60/7/D	Cu	3 × 0.54	3 × 96	T45	F4	28	458.258-38D7A		●	○	●	○	
80.7	3 × 462	75/380/60/7/D	Cu	3 × 0.36	3 × 143	T45	D4	41	468.159-38D7A		●	○	●	○	
<b><math>U_N</math> 480 V    <math>U_c \geq 525</math> V    <math>p = 5.67\%</math> [252 Hz]    <math>I_{lin} 2.2 I_N</math></b>															
6.7	3 × 24	6.3/480/60/5.67/D	Cu	3 × 5.5	3 × 11	T55	A2	5.1	413.074-48B600	●		○	●	○	
8	3 × 29	7.5/480/60/5.67/D	Cu	3 × 4.62	3 × 12	T55	B1	6.4	417.093-48B605	●		○	●	○	
10.6	3 × 38	10/480/60/5.67/D	Cu	3 × 3.47	3 × 17	T55	B2	8	425.094-48B700	○	●	○	●	○	
13.3	3 × 48	12.5/480/60/5.67/D	Cu	3 × 2.77	3 × 21	T55	B2	8.4	428.094-48B70	○	●	○	●	○	
21.2	3 × 77	20/480/60/5.67/D	Cu	3 × 1.73	3 × 33	T55	B5	12.9	440.097-48B700		●	○	●	○	
26.5	3 × 96	25/480/60/5.67/D	Alu	3 × 1.39	3 × 42	T55	C3	16.4	444.126+48B800		●	○	●	○	
53.01	3 × 192	50/480/60/5.67/D	Alu	3 × 0.69	3 × 84	T55	D3	31	458.157+48B800		●	○	●	○	
<b><math>U_N</math> 480 V    <math>U_c \geq 525</math> V    <math>p = 7\%</math> [227 Hz]    <math>I_{lin} 1.8 I_N</math></b>															
13.4	3 × 48	12.5/480/60/7/D	Cu	3 × 3.42	3 × 19	T55	B2	7.9	428.094-48D7A	○	●	○	●	○	
21.3	3 × 77	20/480/60/7/D	Alu	3 × 2.16	3 × 32	T55	C2	13.7	440.125+48D8A0		●	○	●	○	
26.9	3 × 96	25/480/60/7/D	Cu	3 × 1.71	3 × 38	T45	C1	14.6	444.124-48D7A		●	○	●	○	
26.9	3 × 96	25/480/60/7/D	Alu	3 × 1.71	3 × 38	T55	C3	16.1	444.126+48D8A0		●	○	●	○	
32.2	3 × 115	30/480/60/7/D	Alu	3 × 1.43	3 × 48	T55	C4	20	450.326+48D8A0		●	○	●	○	
42.9	3 × 154	40/480/60/7/D	Alu	3 × 1.07	3 × 63	T50	C4	19.5	454.127+48D8A0		●	○	●	○	
53.8	3 × 192	50/480/60/7/D	Cu	3 × 0.86	3 × 76	T45	F4	28.1	458.258-48D7A		●	○	●	○	
53.8	3 × 192	50/480/60/7/D	Alu	3 × 0.86	3 × 76	T55	F6	31	458.260+48D8A0		●	○	●	○	
80.7	3 × 288	75/480/60/7/D	Alu	3 × 0.57	3 × 114	T55	D4	39	468.159+48D8A0		●	○	●	○	
107.5	3 × 384	100/480/60/7/D	Alu	3 × 0.43	3 × 152	T45	D5	44	480.160+48D8A0		●	○	●	○	

DETUNING REACTORS FK-DR D 5.67 %, 6 %, 7 %

## FK-Dr

### ADAPTED RATING (Dla)

#### 5.67 %, 6 %, 7 %



Reactors for capacitors with adapted rating

Power Output $Q_{LC} (U_N)$ (kvar)	Capacitor $C_N$ ( $\mu$ F)	type designation FK-Dr ...	winding	$L_N$ (mH)	$I_{eff}$ (A)	Reactor / Drossel					connection / design				
						Temp. class	size (S.pg. 58)	weight (kg)	order code (standard version)	1	2	3	A	B	
$U_N$ 380 V		$U_c \geq 410V$	$p = 6 \% (245 \text{ Hz})$			$I_{lin} 1.8 I_N$									
10	3 × 57.5	10/380/60/6/Dla	Cu	3 × 2.44	3 × 19	T55	B1	5.6	425.093-3826A0	●	○	○	●	○	
20	3 × 115	20/380/60/6/Dla	Cu	3 × 1.22	3 × 38	T55	C1	12.6	440.124-38270		●	○	●	○	
40	3 × 230	40/380/60/6/Dla	Alu	3 × 0.62	3 × 76	T45	C4	17.5	454.326+3828A0		●	○	●	○	
80	3 × 460	80/380/60/6/Dla	Alu	3 × 0.31	3 × 152	T50	D4	36	470.159+3828A0		●	○	●	○	
$U_N$ 380 V		$U_c \geq 410V$	$p = 7 \% (227 \text{ Hz})$			$I_{lin} 1.8 I_N$									
40	3 × 230	40/380/60/7/Dla	Alu	3 × 0.72	3 × 71	T45	C5	19.8	454.327+3838A0		●	○	●	○	
50	3 × 288	50/380/60/7/Dla	Alu	3 × 0.58	3 × 89	T55	F5	28.2	458.259+3838A0		●	○	●	○	
60	3 × 345	60/380/60/7/Dla	Alu	3 × 0.48	3 × 107	T45	D2	28.1	462.156+3838A0		●	○	●	○	
80	3 × 460	80/380/60/7/Dla	Alu	3 × 0.36	3 × 142	T45	D4	38	470.K59+3838A0		●	○	●	○	
$U_N$ 480 V		$U_c \geq 525V$	$p = 5.67 \% (252 \text{ Hz})$			$I_{lin} 2.2 I_N$									
12.5	3 × 44.5	12.5/480/60/5.67/Dla	Cu	3 × 2.99	3 × 19	T50	B2	7.5	428.094-481700	○	●	○	●	○	
25	3 × 89	25/480/60/5.67/Dla	Alu	3 × 1.5	3 × 39	T45	C3	15.8	444.126+481800		●	○	●	○	
50	3 × 178	50/480/60/5.67/Dla	Alu	3 × 0.75	3 × 77	T45	D3	29.9	458.157+481800		●	○	●	○	
$U_N$ 480 V		$U_c \geq 525V$	$p = 7 \% (227 \text{ Hz})$			$I_{lin} 1.8 I_N$									
12.5	3 × 44.5	12.5/480/60/7/Dla	Cu	3 × 3.68	3 × 18	T55	B2	7.3	428.094-4837A0	○	●	○	●	○	
25	3 × 89	25/480/60/7/Dla	Cu	3 × 1.84	3 × 35	T55	C2	14.6	444.125-4837A0		●	○	●	○	
50	3 × 178	50/480/60/7/Dla	Cu	3 × 0.92	3 × 71	T45	F4	27.3	458.258-4837A0		●	○	●	○	
75	3 × 267	75/480/60/7/Dla	Alu	3 × 0.61	3 × 106	T45	D3	31	468.157+4838A0		●	○	●	○	

- standard design
- other available options

Other ratings, linearities and detuning factors are available on request.



## POWER FACTOR CONTROLLERS

The quality of power supply is an important criterion for safe operation of modern technical equipment. In this context, the functionality of installations for power factor correction and their control and safety features gain a special bearing. Power factor correction banks have the ability to improve power quality, but they can also cause substantial problems.

Modern power factor controllers are self-optimizing and determine the correct power of the capacitor steps within a few trial switchings. If the  $\cos\varphi$  deviates from the programmed limits, the necessary capacitor power for compensation is calculated and a suitable output or a combination of outputs are switched, considering the situation of supply system and power factor correction equipment.

A state-of-the-art power factor controller must also be in a position to monitor all relevant data of equipment and supply system, to alarm in case of overload and, if required, to switch off the whole equipment or capacitor steps temporarily or permanently.

P F E R  
P F R - M



# POWER FACTOR CONTROLLERS



# POWER FACTOR CONTROLLERS

## PFR-X \*\*R / PFR-M \*\*T

### BECAUSE EXCELLENT CAPACITORS ARE NOT ENOUGH

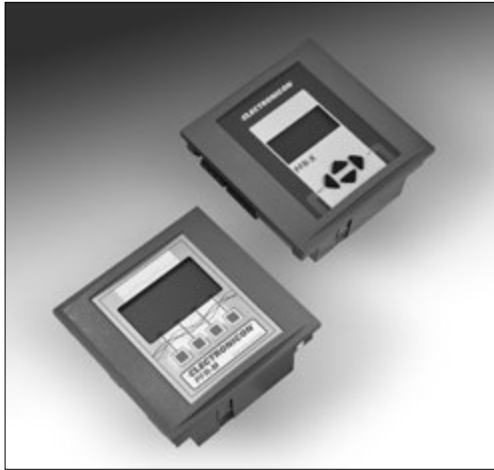

The plug'n'play power factor controllers of our PFR-series calculate the active and reactive power in the mains from the measured current and voltage. Their intelligent control algorithm optimizes the switching sequences and guarantees for short regulation times with a minimum number of switchings. At the same time, equal distribution of switchings for capacitors of equal size extends the lifetime of the capacitors. The integrated connection control immediately detects in which phases voltage and current are measured, and adapts the entire system automatically. The very low current threshold of 15 mA allows for very reliable and exact PF control. 1 A as well as 5 A current transformers can be used without additional manual adjustments. The power supply of PFR-X covers a voltage range of 90...550 V, the PFR-M supply is rated for a voltage range of 207-253 V; it can easily be modified to 100-132 V by a jumper setting.

The rated mains voltage is the only value to be entered before commencing operation. The controller blocks operation to protect the capacitors if the tolerances of this voltage setting are exceeded during operation. All other relevant parameters have been preset by the manufacturer for immediate start of operation in nearly any common configuration. Individual adjustment and optimization of the control parameters is possible at any time, even during operation of the equipment.

Once connected, the size of capacitors or reactors is detected automatically. The life cycle of capacitors is monitored via the degradation of capacitance, and a pre-failure alarm can be provided.

The controllers will operate correctly even if the value of the current transformer ratio has not been entered. Please note that in case of the PFR-X, all display functions related to current measurements will be disabled.

PFR-M can monitor the temperature inside the capacitor cabinet by means of an integrated sensor. For PFR-X, the sensor comes as an optional part which can simply be plugged onto the back of the case. It can activate a fan connected to one of the output relays (PFR-X)/the digital output (PFR-M), or switch off the capacitors if required. External thermostats may be connected in parallel to the integrated temperature sensor (PFR-X)/to the digital input (PFR-M) for monitoring of the temperature in other related cabinets.

For maintenance purposes, all branches can be switched manually.

#### Display

The backlit LC-Display delivers information about the equipment itself and about the mains conditions. It is also necessary for the controller setup.

#### Reported mains conditions

**PFR-X:** Voltage, THD U, current, active power, reactive power, apparent power, frequency,  $\Delta Q$  (power to be compensated), detailed voltage harmonics 3...19,  $\cos\phi$

**PFR-M:** Voltage, THD U, current, THD I, active power, reactive power, apparent power, frequency,  $\Delta Q$  (power to be compensated), detailed voltage and current harmonics 3...30,  $\cos\phi$ , counters



# POWER FACTOR CONTROLLERS

## PFR-X \*\*R / PFR-M \*\*T

### Reported information on the equipment

Passed operation time (hours), number of switchings per branch, max temperature in the equipment, average power factor, actual power per branch, actual percentage of originally installed branch power.  
The  $\cos\phi$  and status of branches are displayed permanently.

### Monitoring

The monitoring functions ensure long and reliable operation of the capacitor equipment:

- zero-voltage tripping to avoid contactor fibrillation
- overvoltage protection
- over-temperature protection
- harmonic monitoring of voltage (PFR-M: voltage and current)
- detection of defect branches (with adjustable threshold value)
- alarm at under-compensation
- maintenance reminder
- fan control (using one of the branch outputs)
- overcurrent
- no current

PFR-M only:

- $\cos\phi$  alarm
- frequency alarm
- overload Q
- overload P
- P export

Malfunctions and status signals of the equipment are indicated in the LC-Display. Malfunctions can also be transmitted through the isolated alarm relay (PFR-X: N-O contact, PFR-M: S-P-D-T contact) or to the digital output (PFR-M only).

### Special Features of PFR-M

- Transistor outputs for the operation with thyristor switches (dynamic compensations)
- Optionally available with relay outputs or as hybrid version (PFR-M 12RT) with 6 relay outputs for static loads and 6 transistor outputs for dynamic loads.
- Fast algorithm for dynamic thyristor operation (switching time ~20 ms).
- Available with optional modbus communication
- Optional 3 phase current measurement

### Modbus Option

The MODBUS extension of the PFR-M offers the possibility to read values from, and modify the settings of, the device. The PFR-M can transmit up to 30 values. The MODBUS-protocol doesn't restrict the user to one single physical transmission system. With the bus-capable RS485 interface of the PFR-M, it is possible to connect more than one controller to a single pair of wires and access the units by use of an ID number. Many commercial devices and PLCs are able to use the MODBUS protocol, either as bus master or slave. Various SCADA solutions are also available from a variety of vendors. So, the integration of the PFR-M in a new or existing bus-system is only a minor issue.

Type	outputs	measurement	Order code
PFR-X 06R	6 relays	1ph	11090.100-06.R
PFR-X 12R	12 relays	1ph	11090.100-12.R
PFR-M 06T	6 transistors	1ph	11050.100-06.T
PFR-M 12T	12 transistors	1ph	11050.100-12.T
PFR-M 12RT	6 relays + 6 transistors	1ph	11050.100-12.H

Type Range

# DATA CHART

## General Technical Data

Feature	PFR-X	PFR-M
Operation voltage	90-550 V rms, 45...65 Hz, 5 VA, 1 ph	230 V (optional 115 V) rms, 45...65 Hz
Measuring voltage	90-550 V rms	50-530V rms
No of output relays	6, 12	6, 12
Output rating	250 V / 5 A	8 ... 32 V DC hybrid option: also 250 V / 5 A
Switching delay	1 s ... 6500 s	20 ms
Display	LCD	graphic LCD
Operating elements	rubber buttons	foil keyboard
Measuring current	15 mA ... 6 A	15 mA ... 6 A
Adjustable transformer ratio	1 ... 9600	1 ... 6500
External Alarm contact	isolated relay, closed contact	isolated relay, changeover contact
Terminals	multiple contact plug (2.5 mm <sup>2</sup> )	multiple contact plug (2.5 mm <sup>2</sup> )
Fuses	to be installed externally (see manual)	to be installed externally (see manual)
Fan control	through branch output	digital output (DO)
Interface	TTL (back)	MODBUS RS485 (optional)
Ambient temperature	-20°C ... 70°C	0°C ... 70°C
Storage temperature	-20°C ... +85°C	-20°C ... +85°C
Humidity	0 % ... 95 % (no condensation)	
Temperature measurement	NTC	
Protection class	IP50 (IP54 with special gasket)	
Front	IP20	
Back	IP20	
Pollution degree	3 (DIN VDE 0110, Pt 1 / IEC60664-1)	
Mounting position	no restrictions	
Case	plastic (UL94: V0)	
Front	metal	
Back	metal	
Dimensions H × W × D	144 × 144 × 58 mm (window size 138 × 138 mm)	
Weight	ca. 0.6 kg	
Standards	DIN VDE 0110 1 (IEC 60664-1:1992) VDE 0411 1 (IEC/DIN EN 61010-1:2001) VDE 0843 20 (IEC/DIN EN 61326: 1997 + A1:1998 +A2: 2000) GOST 15150-69 UL 508 – Industrial Control Equipment CSA C22.2 No. 14-M95 - Industrial Control Equipment	
Approval marks	UL, Rostest, c-UL	



### CE Conformity

The controller is declared to conform to the following European Directives:

2014/35/EU Low-Voltage Directive

2004/108/EG EMC directive

# ANNEX



## Allgemeine Sicherheitshinweise Starkstromkondensatoren

Gemeinsame Sicherheitshinweise der im ZVEI - Zentralverband Elektrotechnik- und Elektronik e. V. - organisierten Hersteller von Starkstromkondensatoren

### I. Geltungsbereich

Dieses Sicherheitsdatenblatt gilt für die im Folgenden genannten Starkstromkondensatoren und Normen. Damit soll der Stand der Technik, der im Regelfall bei allen einschlägigen Liefer- und Leistungsverträgen einzuhalten ist, beschrieben werden.

1. Leistungskondensatoren für Blindstromkompensation (PFC) bis 1000 V	IEC / DIN-EN 60831 und 60931
2. Leistungskondensatoren für Blindstromkompensation (PFC) über 1000 V	IEC / DIN-EN 60871
3. Leistungskondensatoren für induktive Wärmeerzeugung (PFC)	IEC / DIN-EN 60110
4. Kondensatoren für die Leistungselektronik (PEC)	IEC / DIN-EN 61071
5. Kondensatoren für Bahnanwendungen (PEC)	IEC / DIN-EN 60881
6. Leuchtenkondensatoren (AC)	IEC / DIN-EN 61048/49
7. Motorkondensatoren (AC)	IEC / DIN-EN 60252
8. Überspannungsschutzkondensatoren	VDE / 0560-3 (derzeit keine gültige IEC vorhanden)

### II. Allgemeine Sicherheitsregeln

Starkstromkondensatoren sind elektrische Ladungsspeicher und deshalb stets mit Vorsicht zu handhaben. Sie können auch nach dem Abschalten über längere Zeiträume noch mit lebensgefährlich hohen Spannungen geladen sein. Gleiches gilt für alle Anlagenteile und Geräte, die in elektrisch leitender Verbindung zum Kondensator stehen. Grundsätzlich sind die allgemeinen Regeln der Elektrotechnik für den Umgang mit spannungsführenden Teilen in elektrischen Anlagen zu beachten.

### III. Allgemeine Lager- und Einsatzbedingungen

- Grundsätzlich sind die Montage, Applikations- und Wartungshinweise des Herstellers und die einschlägigen Normen zu beachten.
- Kondensatoren dürfen zu keinem Zeitpunkt außerhalb der spezifizierten Temperaturbereiche gelagert oder eingesetzt werden.**
- Kondensatoren dürfen nicht in korrosiver Atmosphäre gelagert oder betrieben werden, insbesondere nicht wenn Chloride, Sulfide, Säuren, Laugen, Salze, organische Lösemittel oder ähnliche Substanzen auftreten.
- In staub- und schmutzgefährdeter Umgebung ist eine regelmäßige Kontrolle und Wartung, insbe-

sondere der Anschlussklemmen und Isolatoren, unbedingt erforderlich um eine Kriechwegbildung zwischen potentialführenden Teilen untereinander und/oder zum Schutzleiter/Erde zu verhindern.

- Die im Datenblatt angegebenen maximalen Temperaturen (incl. Eigenerwärmung), Spannungen, Ströme, Leistungen, thermische Widerstände, Frequenzen, Entladezeiten und Schalthäufigkeiten sind einzuhalten.**
- Für ausreichende Abführung der Verlustwärme (Belüftung, Kühlung) oder im Fehlerfall austretende Gase und Flüssigkeiten ist Sorge zu tragen. Geforderte Mindestabstände z. B. zu Wärmequellen sind einzuhalten.**
- Angegebene Drehmomente für elektrische Anschlüsse und Befestigungselemente sind einzuhalten.
- Mechanisch oder elektrisch beschädigte, undichte oder anderweitig vorgeschädigte Kondensatoren dürfen nicht eingesetzt oder weiterverwendet werden.
- Vorhandene Schutzeinrichtungen der Kondensatoren dürfen nicht manipuliert, entfernt oder in ihrer Funktion beeinträchtigt werden.

### IV. Schutzeinrichtungen

- Die folgende Tabelle gibt einen Überblick über die bekannten internen Schutzeinrichtungen:

Schutzeinrichtung/ Schutzmechanismus	Anwendungsbereich		
	PEC	PFC	AC
Ohne Schutzeinrichtungen	x		
Ausschließlich Selbstheilung	x	x	x
<u>Einzel</u> oder <u>in Kombination:</u>			
Verbesserte Selbstheilung	x		
Überdruckunterbrecher	x	x	x
Überdruckschalter	x	x	x
Überdruckventil	x	x	
Überdruckmembrane	x		
Verstärktes Gehäuse	x	x	
Segmentierter Film	x	x	x
Wickelsicherung		x	x
Thermosicherung			x

- Interne Schutzeinrichtungen bieten einen Basischutz bei bestimmten inneren Fehlern, Alterserscheinungen und Überlastfällen.
- Interne Schutzeinrichtungen sind allein nicht ausreichend, um alle im Fehlerfall denkbaren Gefahren abzuwenden. Die so genannte Selbstheilfähigkeit darf nicht mit Ausfallsicherheit gleichgesetzt werden.
- Die meisten internen Schutzeinrichtungen können die Spannung nur innerhalb des Kondensators unterbrechen. Sie sind keine Sicherungen im

klassischen Sinne wie Leitungs- oder Geräteschutzsicherungen, die die Spannung vor dem fehlerhaften Anlagenteil unterbrechen.

5. Es ist empfehlenswert interne Schutzeinrichtungen durch externe Schutzeinrichtung zu ergänzen wie z.B.:
  - Kurzschlusschutz durch Sicherungen oder Leistungsschalter / Schutzrelais
  - Überlastschutz für Grund- und Oberschwingungen mittels Strommessung
  - Unsymmetrieschutz
  - Temperaturüberwachung
6. Schutzeinrichtungen unterliegen, abhängig vom Schutzmechanismus, technischen und funktionalen Grenzen, deren Überschreitung zwangsläufig zu Fehlern führt. Solche Überschreitungen können sein: **Übertemperatur, Überspannung, falsche Applikation, falsche Installation, mangelhafte Wartung, mechanische Beschädigung, Betrieb außerhalb der technischen Grenzen der Spezifikation.**

## V. Risikofaktoren für den Kondensator

Die Risikofaktoren, die am häufigsten zu Kondensatorschäden und möglicherweise auch zum Versagen der internen Schutzeinrichtungen führen, sind:

1. Überschreiten der zulässigen Temperatur an der Kondensatoroberfläche (jede Temperaturerhöhung von 7 °K halbiert die Lebenserwartung)
2. Spannungserhöhungen, Überströme und hohe Einschaltströme, auch wenn sie nur kurzzeitig oder periodisch auftreten (eine dauerhafte Erhöhung der Betriebsspannung des Kondensators von 8 % halbiert die Lebenserwartung)
3. Netzüberschwingungen, Anregung von Resonanzen durch Oberschwingungen oder Flicker, auch wenn sie nur kurzzeitig oder periodisch auftreten
4. Alterungserscheinungen an Leuchtmitteln und damit verbundene Übertemperatur oder hohe UV-Belastung
5. Ausfall anderer Bauelemente in einer gemeinsamen Schaltung und damit verbundene Überspannungen oder Überströme
6. Wechselwirkungen mit anderen Blindleistungselementen, auch parasitären Kapazitäten (Kabel) oder Induktivitäten, in gemeinsamen Schaltungen
7. Die bestandene Prüfung nach Kondensatornorm garantiert keine umfassende Sicherheit gegen Überlastungsmöglichkeiten
8. Beim Betrieb bestimmter thyristorgeschalteter Kondensatoranlagen können an den Kondensatoren nicht eingeschalteter Kompensationsstufen dauerhaft hohe Gleichspannungen auftreten. Diese DC-Spannungen sind bei der Auslegung der Kondensatoren sowie deren Entladeeinrichtungen zu berücksichtigen.

## VI. Risiken im Fehlerfall

1. Starkstromkondensatoren können aufgrund ihrer gespeicherten Energie und/oder ihrer Eigenschaften beim Betrieb in Netzen mit hohen Kurzschlussleistungen im Fehlerfall ein erhebliches Risiko darstellen.

2. Starkstromkondensatoren können bei fehlenden, falsch dimensionierten oder versagenden internen oder externen Schutzeinrichtungen aktiv ausfallen. Sie können platzen, brennen oder im Extremfall explodieren.
3. Im Schadensfall austretende Gase (z. B. Kohlenwasserstoffe als Zersetzungsprodukte der eingesetzten organischen Isoliermaterialien) sind brennbar und können explosive Gemische ergeben. Die Brandlast eines Starkstromkondensators beträgt ca. 40 MJ/kg. Dabei ist zu beachten, dass abhängig von der Größe und bezogen auf die Gesamtmasse des Kondensators bei kleinen Baugrößen etwa 55% und bei großen maximal 75% aus brennbaren Materialien bestehen.

## VII. Risikominimierung

1. Der Kondensatorhersteller kann nicht alle Belastungsmöglichkeiten eines Starkstromkondensators voraussehen und in der Konstruktion berücksichtigen. Hier trägt der Anwender entscheidende Mitverantwortung. Schon deshalb sollten bei der Kondensatorauswahl Sicherheit und Qualität an erster Stelle stehen. **Deshalb ist dringend zu empfehlen, Kondensatoren mit entsprechenden internen Schutzeinrichtungen einzusetzen.**
2. Kondensatoren sind im Vorfeld der Anwendung auf ihre Eignung für den Anwendungsfall zu prüfen, dabei sind alle Einflüsse (Parameter) zu berücksichtigen. Die bedenkenlose Übernahme in eine Anwendung kann schwerwiegende Folgen haben.  
Besonders bei sensiblen Anwendungen müssen die internen Schutzeinrichtungen der Kondensatoren vom Anwender durch geeignete externe Schutzmaßnahmen ergänzt werden. **Externe Schutzmaßnahmen sind beim Einsatz von Kondensatoren ohne interne Schutzeinrichtungen sogar zwingend erforderlich**
3. Grundsätzlich ist beim Einsatz von Leistungskondensatoren durch geeignete Maßnahmen dafür zu sorgen, dass sowohl im Betriebs-, als auch im Schadensfall keine Gefahren für Menschen, Tiere und Sachen entstehen. Dies gilt für Kondensatoren ohne und mit Schutzeinrichtungen. **Dazu ist eine regelmäßige, fachgerechte Prüfung und Wartung erforderlich.**
4. Die im ZVEI organisierten Starkstromkondensatorhersteller sind gerne bereit, den Anwender schon im Vorfeld des Einsatzes zu beraten und konkrete Anwendungsempfehlungen zu geben, sowie Serviceleistungen anzubieten.

Stand: Juli 2013

Verantwortlich für den Inhalt  
ZVEI – Zentralverband Elektrotechnik- und  
Elektronikindustrie e.V.  
Fachverband Starkstromkondensatoren  
Lyoner Straße 9  
60528 Frankfurt am Main  
Fon: 069 6302 – 251  
Fax: 069 6302 – 407  
Mail: starkstromkondensatoren@zvei.org

*Trotz größtmöglicher Sorgfalt kann keine Haftung für Inhalt und Vollständigkeit der Angaben übernommen werden.*

# CERTIFICATES

**Überwachte Fertigungsstätte**  
**Approved Place of Manufacture**

**ELECTRONICON Kondensatoren GmbH**  
 Keplerstraße 2  
 07549 Gera

Fertigungsstättennummer: 30003593

Die Überwachung der Fertigungsstätte erfolgte nach dem europäischen Werksinspektions-Verfahren auf Basis der folgenden Schriftstücke / This surveillance of the factory was performed according to the European Factory Inspection Procedure based on the following documents:

**ECS/CG 021 - 024: 2014**  
**Werksinspektionsverfahren, Harmonisierte Anforderungen /**  
**Factory Inspection Procedure - Harmonized Requirements**  
 Die Anforderungen wurden erfüllt / The requirements have been fulfilled.

Datum der letzten Inspektion / Date of last inspection:  
 2015-09-17

Produkt-Kategorie: Siehe Anhang /  
 Product Category: See Appendix

**VDE Prüf- und Zertifizierungsinstitut GmbH**  
**VDE Testing and Certification Institute**  
 Inspektionen, Konformitätsüberwachung, Intern. Service  
 Inspection, Conformance, Intern. Service

*Thomas Sitz*  
 Thomas Sitz  
 Datum / Date: 2015-10-13

Merke! Diese Zertifikate sind nur für die Fertigungsstätte und das Werk zu verwenden. / Note! These certificates are only for the factory and the plant to be used.

**VDE**  
 INSTITUT

**CERTIFICATE** 

for the management system  
 according to ISO 9001:2008

The proof of the conforming application with the regulation was furnished and in accordance with certification procedure it is certified for the company

**ELECTRONICON®**  
**ELECTRONICON Kondensatoren GmbH**  
 Keplerstraße 2  
 07549 Gera / Germany

Scope

Development, production and sale of DC/AC capacitors for high, medium and low voltage, reactors, controllers, capacitor modules, accessories and banks, metal coating of film

Certificate Registration No.: TIC 15 100 9534 Valid until: 2018-05-31  
 Valid from: 2015-06-08

Audit Report No.: 3330 206V 00 Initial certification: 1999

This certification was conducted in accordance with the TIC auditing and certification procedures and is subject to regular surveillance audits.

*A. Drosch*  Jena, 2015-06-08  
 TÜV Thüringen e.V.  
 Certification body for systems and personnel



The certification body is accredited according to DIN EN ISO 9001:2008  
 Zertifizierungsstelle des TÜV Thüringen e.V. - Jena, Jena-Platz 1, D-07745 Jena - Tel: +49 (0)36 30961-10, certification@tuev-thueringen.de

  
 International Certification Group

**Certified Management System**

It is hereby confirmed that company

**ELECTRONICON Kondensatoren GmbH**  
 Keplerstraße 2  
 07549 Gera

including the sites:

**An der Silbergrube 4-6**      **Am Steingarten 12**  
 07551 Gera                      07554 Gera

has fully implemented a energy management system in accordance with the standard

**DIN EN ISO 50001:2011**

for the following scope of application:

Development, manufacture and sale of DC and AC capacitors for high, medium and low voltages, reactors, controllers, capacitor assemblies, capacitor systems and accessories, metallization of films

 Certificate registration no.: 349056  
 This certificate is valid until: 20.12.2018  
 Chemnitz, 21.12.2015

*R. Klein*  
 R. Klein  
 Certifying Body

ICG Zertifizierung GmbH, Wipperfurthstraße 3, D-08247 Chemnitz / Germany



# CERTIFICATES

**Certificate of Compliance**

Certificate Number: 20110111-0211978 Page 1 of 1  
 Report Reference: 0211019, 2011 January 11  
 Issue Date: 2011 January 11

**UL Underwriters Laboratories**

**Issued to:** ELECTRONICON KONDENSATOREN GMBH  
 KEPLERSTRASSE 2  
 07548 GERA GERMANY

**This is to certify that representative samples of** CAPACITORS  
 MKP, MKP7, MKP8

*Have been investigated by Underwriters Laboratories Inc. (UL) in accordance with the Standard(s) indicated on this Certificate.*

**Standard(s) for Safety:** Standard for Capacitors, UL 818, Fifth Edition  
 CSA C22.2 No. 190-M1905, The Standard for Capacitor for Power Factor Correction, 1st Edition

**Additional Information:** See UL On-Line Certification Directory at [www.ul.com](http://www.ul.com) for additional information.

Only those products bearing the UL Recognized Component Mark for the U.S. and Canada should be considered as being covered by UL's Recognition and Follow-Up Service and meeting the appropriate U.S. and Canadian requirements. The UL Recognized Component Mark for the U.S. generally consists of the manufacturer's identification and rating number, model number or other product designation as specified under "Marking" for the particular Recognition as published in the appropriate UL Directory. It is a representative means of identifying products that have been produced under UL's Component Recognition Program. UL's Component Recognition Mark may be used in conjunction with the Recognized Component Mark. The Recognized Component Mark is required when specified in the UL Directory pertaining to the component or under "Marking" for the individual recognition. The UL Recognized Component Mark for Canada consists of the UL Recognized Component Mark for Canada and the manufacturer's identification and rating number, model number or other product designation as specified under "Marking" for the particular Recognition as published in the appropriate UL Directory.

**Look for the UL Recognized Component Mark on the product**

William R. Carney  
 Director, North American Certification Programs  
 Underwriters Laboratories Inc.  
 Any information and documentation provided by Marking services is provided as a service of Underwriters Laboratories Inc. for the information and documentation provided by the manufacturer. Underwriters Laboratories Inc. does not assume any liability for the accuracy of the information provided by the manufacturer.

**Certificate of Compliance**

Certificate: 1162402 Master Contract: 185434 (LR 101373)  
 Project: 126494 Date Issued: January 3, 2002

**Issued to:** Elektronicon Kondensatoren GmbH  
 Keplerstrasse 2  
 Gera, 07548  
 GERMANY  
 Attention: Mr. Stefan Hockstadt

*The products listed below are eligible to bear the CSA Mark shown with adjacent indicators 'C' and 'US'*

**Issued by:** N. Crutcher  
**Authorized by:** Brian Reinhardt, Operations Manager

**PRODUCTS**  
 CLASS 9071 01 - CAPACITORS - For Power Factor Correction  
 CLASS 9071 02 - CAPACITORS - For Power Factor Correction - CERTIFIED TO U.S. STANDARDS

Series MKP7, LEYDEN, SYSTEM ELECTRIC, EKO, AENER, ELSPEC, 250 to 600V ac, indoor type, 1 and 3 phase, min size 75 x 176mm, max size 136 x 226mm, 5VAr as follows:

V	Hz	Maximum Rating	
		(Rated Power (VAr))	(kVAr)
250	60	0,81	30
250	50	0,51	25
380	60	1,60	60
400	60	1,84	60
400	50	1,54	60
415	50	1,65	60
440	60	2,23	60
440	50	1,86	60
480	60	2,43	60
525	50	2,64	60
600	60	4,14	60

The 'C' and 'US' indicators adjacent to the CSA Mark signify that the product has been evaluated to the applicable CSA and ANSI/UL Standards, for use in Canada and the U.S., respectively. The 'US' indicator includes products eligible to bear the NRTL indicator. NRTL, an Underwriter's Testing Laboratory, is a designation granted by the U.S. Occupational Safety and Health Administration (OSHA) to laboratories which have been recognized to perform certification to U.S. Standards. 2002-01995-0001/0102

**Certificate of Compliance**

Certificate Number: 20111107-0212126A Page 1 of 1  
 Report Reference: 0212105-20111108  
 Issue Date: 2011-02-15/MSBEE-07

**UL Underwriters Laboratories**

**Issued to:** ELECTRONICON KONDENSATOREN GMBH  
 KEPLERSTRASSE 2  
 07548 GERA GERMANY

**This is to certify that representative samples of** COMPONENT - POWER CIRCUIT AND MOTOR-MOUNTED APPARATUS  
 See Addendum Page

*Have been investigated by Underwriters Laboratories in accordance with the Standard(s) indicated on this Certificate.*

**Standard(s) for Safety:** UL508  
 CAN/CSA C22.2 No. 14-2010

**Additional Information:** See UL On-Line Certification Directory at [WWW.UL.COM](http://WWW.UL.COM) for additional information.

Only those products bearing the UL Recognized Component Mark for the U.S. and Canada should be considered as being covered by UL's Recognition and Follow-Up Service and meeting the appropriate U.S. and Canadian requirements. The UL Recognized Component Mark for the U.S. generally consists of the manufacturer's identification and rating number, model number or other product designation as specified under "Marking" for the particular Recognition as published in the appropriate UL Directory. It is a representative means of identifying products that have been produced under UL's Component Recognition Program. UL's Component Recognition Mark may be used in conjunction with the Recognized Component Mark. The Recognized Component Mark is required when specified in the UL Directory pertaining to the component or under "Marking" for the individual recognition. The UL Recognized Component Mark for Canada consists of the UL Recognized Component Mark for Canada and the manufacturer's identification and rating number, model number or other product designation as specified under "Marking" for the particular Recognition as published in the appropriate UL Directory.

**Look for the UL Recognized Component Mark on the product**

William R. Carney  
 Director, North American Certification Programs  
 Underwriters Laboratories Inc.  
 Any information and documentation provided by Marking services is provided as a service of Underwriters Laboratories Inc. for the information and documentation provided by the manufacturer. Underwriters Laboratories Inc. does not assume any liability for the accuracy of the information provided by the manufacturer.

CERTIFICATES

# PACKING DETAILS

## Capacitors

Type Box	L × B × H mm	Box/ pallet
FB 0	383 × 203 × 193	80
FB 2	383 × 203 × 148	80
FB 7	383 × 203 × 208	80
FB 8	393 × 153 × 270	80
FB 9	393 × 153 × 320	70
FB 10	393 × 153 × 370	56
FB 12	393 × 153 × 330	70

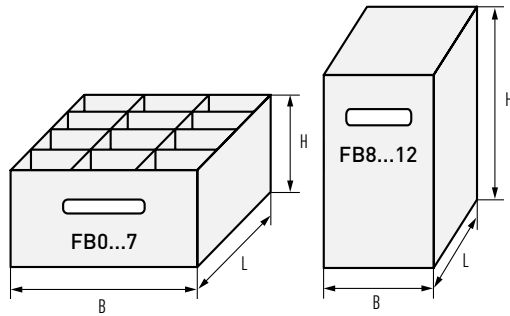

**Box**  
Carton, sealed with adhesive paper tape

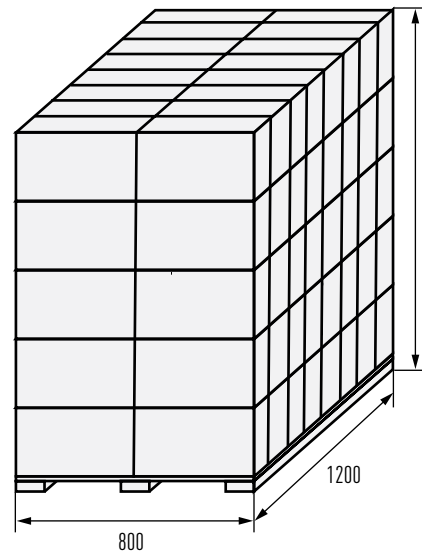

**Pallet**  
Standard Euro-pallet  
(fumigated if required), wrapped in PP-foil  
air freight ≤ 1600  
see freight ≤ 1800

## Reactors

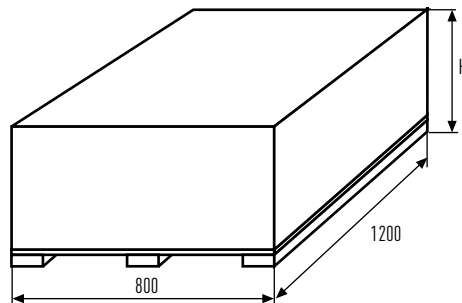

**Pallet**  
Wooden frame on standard Euro-pallet  
(fumigated if required)



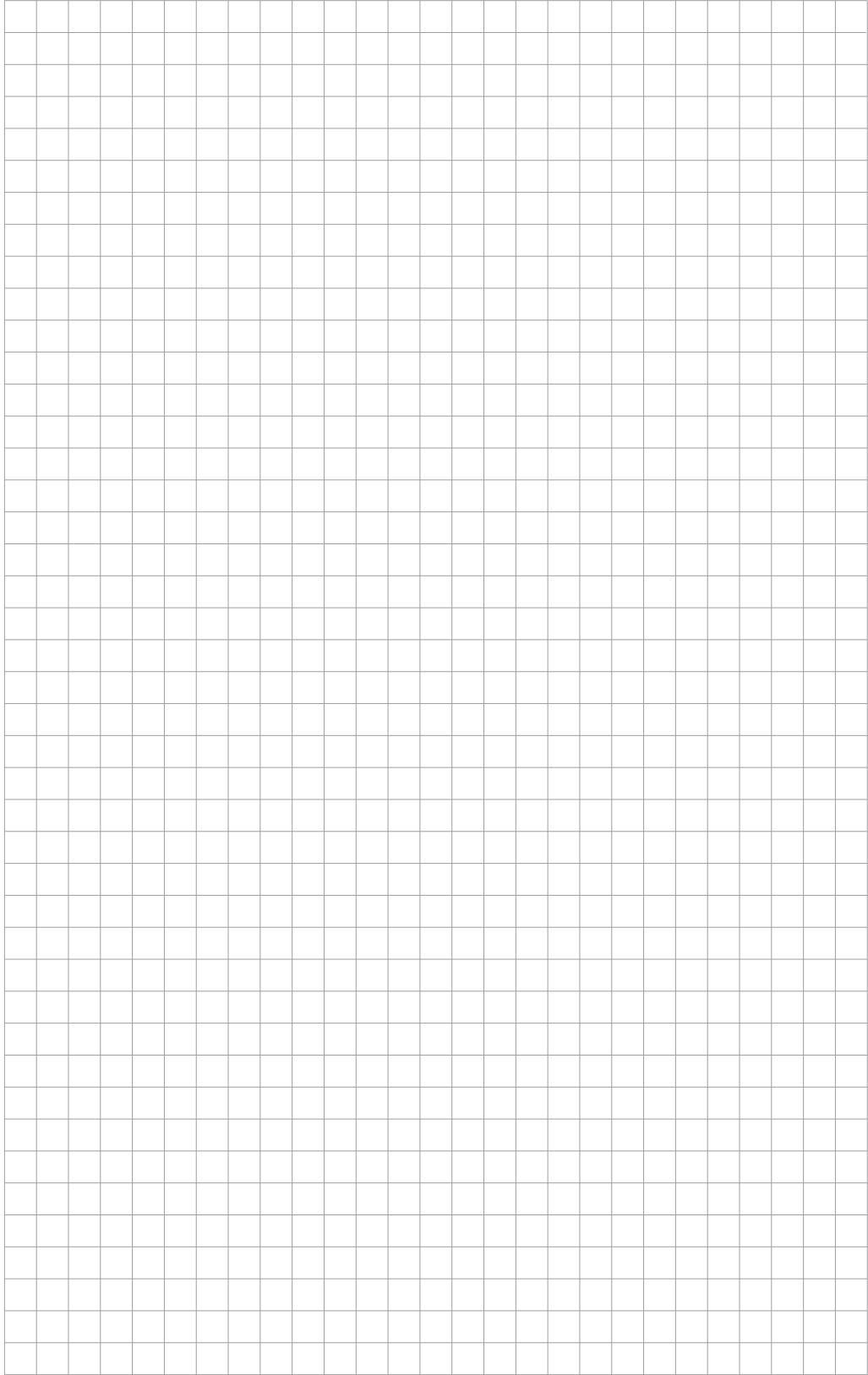



Also available:  
**Capacitors for Power Electronics**

AC and DC capacitors with integrated safety mechanism  
E62 AC/DC E62-3ph AC Filter E63 DC

Low-inductance capacitors  
E50 PK16™ DC E53 AC/DC E61 DC

Low-inductance High-voltage capacitors  
E51

AC and DC capacitors with large capacitance  
E56 DC E59 AC/DC E70 AC E50.U SR17™ DC

CAPACITORS

**ELECTRONICON**®

*always in charge*



## EXCELLENT EXPERIENCE IN CAPACITOR MAKING FOR OVER 75 YEARS

Gera has been a centre of capacitor making since 1938. ELECTRONICON Kondensatoren GmbH which emerged from previous RFT/VEB ELEKTRONIK Gera in 1992, has become one of Europe's leading capacitor manufacturers supplying customers worldwide and being an open and competent partner for manufacturers and users of power factor correction equipment, for many manufacturers of drives, power electronics, home appliances, and for the lighting industry. Regular investments in advanced and environmentally sound technologies guarantee the highest levels in manufacture and quality to modern standards which are approved and monitored by leading certification authorities.

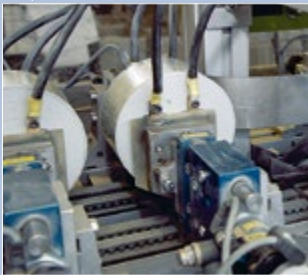

In today's globalised competition, we distinguish ourselves by

- Absolute reliability and safety of our products
- Close co-operation between manufacturer and client to meet both technical and commercial requirements
- Improvement and development of our technical expertise in capacitor design and manufacture, as well as film coating, with special attention paid to the MKPg-technology
- Early identification and incorporation of new trends and methods in the manufacturing of capacitors
- Flexibility and punctual fulfilment of our commercial obligations

Our experienced development engineers are competent and responsible for both implementing the latest technical trends applicable to our products and ensuring that our products adapt to the challenges of traditional and new markets. The close and intense co-operation between the departments of Marketing & Sales, Research & Development, and Production has become the keystone of our success. ELECTRONICON is continually striving to establish a similarly close and interactive relationship with its distributors and direct clients both in home and overseas markets, to become not just one out of many suppliers, but your preferred partner for ideas and solutions.

# ELECTRONICON®

Germany • 07549 Gera • Keplerstrasse 2  
Fon +49 365 / 734 61 00 • Fax +49 365 / 734 61 10  
E-Mail: [sales@electronicon.com](mailto:sales@electronicon.com), [www.electronicon.com](http://www.electronicon.com)

